

VERDERFLEX[®] **SMART**

Verderflex Smart[®]
Peristaltic Tube Pump

**Safety; operation and
maintenance manual
(F-Series)**



Solutions in Pumping Technology



Warning Symbols

Signal words designate a degree or level of hazard seriousness. They are used in this manual in accordance with ANSI Z535.4-1991 and are defined as follows:



The symbol shown above is used to identify topics of primary safety concern and call attention to instructions concerning your personal safety. Look out for this symbol, it highlights important safety precautions, and means "ATTENTION! BE ALERT! YOUR PERSONAL SAFETY IS INVOLVED!" Read the message that follows and be alert to the possibility of personal injury.

 **DANGER**

Indicates an imminently hazardous situation, which, if not avoided will result in death or serious injury. This signal word is limited to most extreme situations

 **WARNING**

Indicates a potentially hazardous situation, which if not avoided could result in death or serious injury.

Trademarks

Some products mentioned in this manual or used in combination with Verderflex[®] Smart-F pumps are, or are asserted to be, proprietary names or trademarks. VERDER. acknowledges the rights of the respective owners of proprietary names and trademarks. Should trademarks not be indicated does not imply that they have acquired for legal purposes a non-proprietary status nor is any judgement implied concerning their legal status.

TABLE OF CONTENTS

DISCLAIMER OF WARRANTY AND LIMITATIONS OF LIABILITY	4
1. INTRODUCTION	6
2. THE VERDERFLEX® SMART-F PUMP	7
3. SAFETY ISSUES	8
3.1 General Safety Notes.....	8
3.2 Installation, Usage and Operation	8
3.3 Maintenance and Repair	9
3.4 Temperature during transport and operation	9
4. THE PUMP HEAD	10
4.1 Description of the Pump Head	10
4.2 Optional Tube Saddle Status Detection SSD.....	10
4.3 Changing and Cleaning the Pump Head	10
4.4 Installing a multi-channel pump head	12
4.5 Changing the tube	13
5. ASSEMBLY OF THE VERDERFLEX® SMART-F PUMP	14
6. TUBE SELECTION AND OPERATION PARAMETERS.....	16
6.1 Chemical Compatibility Testing	17
6.2 Reducing Pulsation	18
6.2.1 Use of a six-roller rotor	18
6.2.2 Use of two-channel pump head.....	18
7. PUMP CURVES	20
7.1 FREE FLOW CURVES.....	20
7.2 SUCTION CORRECTION CURVES	22
7.3 Discharge Pressure Limitation.....	24
8. FAULT FINDING	26
9. SPARE PARTS	27
10. WARRANTY & CONTACT DETAILS.....	29
COMPLAINTS PROCEDURE.....	29
VERDER GROUP LITERATURE.....	30
DISTRIBUTOR CONTACT DETAILS:.....	30
VERDER CONTACT DETAILS:	30

Disclaimer of Warranty and Limitations of Liability

This pump is warranted against defects in workmanship and material under normal use (rental pumps excluded) for two years from date of purchase. This is limited to the extent that Verder will at its option replace, repair or refund, in full, the purchase price of the instrument or any part thereof manufactured by VERDER, which in our opinion is defective. This is subject to the instrument having been operated in strict accordance with this manual, and having not been subjected to tampering, abuse or exposed to highly corrosive and/or unspecified explosive conditions.

This warranty does not cover the conditions arising as follows:

- Failure of VERDER manufactured parts or components including tube & rollers, due to normal wear or any damage or failure, that in VERDER's judgement, arises from misuse
- Failure to implement the necessary safety procedures for use in the European Community of a pump within an explosive atmosphere as laid down in latest EC Atex directive from 1st July 2003. The standard Verderflex[®] Smart-F[™] pump is not ATEX certified, please see further advice below
- Failure to disclose the (intended or unauthorized) use of a pump within a known explosive atmosphere

VERDER MAKES NO WARRANTIES, EXPRESSED OR IMPLIED, INCLUDING, WITHOUT LIMITATION, ANY WARRANTIES OF FITNESS OR MERCHANTABILITY, EXCEPT AS EXPRESSLY SET FORTH ABOVE. VERDER SHALL NOT BE LIABLE FOR ANY INJURIES, LOSSES OR DAMAGES INCLUDING, BUT NOT LIMITED TO ANY PERSONAL INJURIES, ANTICIPATED OR LOST PROFITS, INCIDENTAL DAMAGES, CONSEQUENTIAL DAMAGES, COSTS, TIME CHARGES, OR OTHER DAMAGES OR LOSSES, IN CONNECTION WITH THE INSTRUMENT, ITS USE OR ANY REPLACEMENT PARTS THEREOF.

Full completion of the warranty card is essential in order to be covered by VERDER's outstanding warranty schemes. Please be aware of the declaration that you undertake to use only Verderflex[®] spare parts - this is an essential part of the warranty scheme and is legally binding. The card will also act as a record of your dealings with VERDER and its distributors.

This warranty is voided if the customer fails to follow any and all instructions, warnings or cautions in this Verderflex[®] Smart-F Pump Safety, Operation and Maintenance Manual. VERDER has made every effort to illustrate and describe the product(s) in this manual. Such illustrations and descriptions are, however, for the sole purpose of identification and do not express or imply a warranty that the products are merchantable or fit for a particular purpose, or that the products will necessarily conform to the illustration or descriptions

If a manufacturing defect is found, VERDER will replace or repair the instrument or replace any defective part thereof without charge. However, VERDER's obligation hereunder does not include the cost of transportation of the instrument to VERDER or its return to the customer; these costs must be borne by the customer. VERDER assumes no responsibility for damage in transit any claims for such damage should be presented to the carrier by the purchaser. In addition, instead of replacing or repairing the instrument as aforesaid, VERDER may, at its sole option, take back the

defective instrument and reimburse the customer for the purchase price in full settlement of any and all potential claims related to the purchase or use of the Verderflex[®] Smart-F pump

⚠ DANGER

Peristaltic Tube Pumps are frequently used in medical applications. The Verderflex[®] Smart-F is not certified for such applications and **MUST NOT** be used wherever the pump is directly connected to a patient.

⚠ DANGER

The standard Verderflex[®] Smart-F pumps are **NOT** ATEX certified and must not be used in hazardous and / or an explosive atmosphere. We can however supply, to special order, ATEX compliant pumps manufactured from conductive materials which are certified to EEx IIG T4. In conjunction with an ATEX certified motor and gearbox, such a pump head can be assembled into an ATEX certified Verderflex[®] Smart-F pump. Such a pump would be suitable for operation in these hazardous environments, provided that the pumped fluids have a conductance of at least 50 pS/m.

Due to material conductivity limitations the Verderflex[®] F40 cannot be supplied to ATEX requirements.

1. Introduction

The Verder Group of companies have offices located in Austria, Belgium, China, Czech Republic, France, Germany, Hungary, Japan, Norway, Poland, Romania, Slovakia, South Africa, The Netherlands, United States and the United Kingdom. A network of worldwide distributors supports our products in other countries. A full list is available on .verderflex.com. The Verder Group's headquarters are in Holland.

VERDER in-house designers and application engineers have developed the Verderflex[®] Smart-F range of peristaltic tube pumps. Full product training and documentation is available. VERDER will not accept responsibility for any malfunction of the pump caused by a failure to follow these operating procedures. If operators do not read and understand this manual, they are not considered by VERDER to be qualified to assemble, install, operate or maintain this equipment. As pumps are an integral part of an overall process, it is essential for the successful completion of the total process for the pump to be working to its full potential, and for the operator to be fully conversant with the operating principles of the tube pump.

VERDER is accredited to both the ISO 9000:2000 quality & ISO 14001:2004 environmental quality standards.

It is VERDER policy to supply all of its documentation in a number of languages and software options. Your Verder distributor will be able to assist you with the options available.

VERDER recognizes its responsibilities to its customers around the world, and will always seek to meet or exceed their reasonable expectations. VERDER welcomes customer comments, feedback and input into the development of procedures and products. Should you have any issues, which you wish to comment on, please return your comments to your local Verder distributor who will then forward them to VERDER for further action.

The latest version of this manual, product updates & notifications can be found on our website at .verderflex.com.

2. The Verderflex[®] Smart-F Pump

Description

- The Verderflex[®] Smart-F pump is a peristaltic pump designed for laboratories and industrial applications.
- Like VERDER, Verderflex[®] and Verderflex[®] Dura industrial hose pumps, the Verderflex[®] Smart-F is suitable, within reason, for pumping viscous fluids, fluids with solid content and fluids that are prone to degassing. The pump can run dry for a prolonged period of time and is self-priming.
- The Verderflex[®] Smart-F range is a series of pumps with industrial gear motor units drive and optional inverter controls. Please contact Verderflex[®] or your local distributor for more information.



3 Safety Issues



3.1 General Safety Notes

- Follow all instructions in this Safety, Operation and Maintenance Manual. Store the Safety, Operation and Maintenance Manual close to the Verderflex[®] Smart-F Pump.
- The Health and Safety of people, the environment and the successful operation of the process is very much dependent upon the actions of the operator of the Verderflex[®] Smart-F Pump.
- The user must read this Safety, Operation and Maintenance Manual carefully before you start using the Verderflex[®] Smart-F Pump, in order to avoid errors or damage to the equipment. The Verderflex[®] Smart-F pump must only be installed and operated by fully trained personnel. Particular emphasis must be given to the connection of the pump to local electricity supplies and compliance with local, regional and national electrical installation guidelines. Only suitably qualified personnel may connect or disconnect Verderflex[®] Smart-F Pump from such supplies. This should only be done under secure conditions. (i.e. The pump should be switched off, isolated and disconnected from the mains.)
- Only permitted accessories and approved original replacement parts may be used. The use of other parts can lead to unknown risks, which should be avoided at all times. The efficiency and safety of the Verderflex[®] Smart-F pump is only guaranteed when the required checks, maintenance, and repairs are carried out by a Verder Service Engineer or by personnel authorized by Verder.
- For queries and spare part orders include the product label information (in particular the pump serial number) as this enables us to supply the correct items.
- The sale, construction, installation, and/or use of Verderflex[®] Smart-F pumps may be governed by local legislation and / or standards. Although VERDER attempts to ensure that all our products fulfil all major international standards such fulfilment cannot be guaranteed. In addition we assume no liability regarding the use, installation and operation of Verder products. Before purchasing or using these units, please obtain information concerning the relevant local regulations.

3.2 Installation, Usage and Operation

- The Verderflex[®] Smart-F pump must be turned on & off by a suitably installed mains isolation switch when inserting the tubes or whilst cleaning the pump.
- Under no circumstances must the operator interfere any the interlock system that may be fitted as this may protect the user from exposure to moving parts. Please note that the unguarded pump rotor can cause injuries. DO NOT place any body parts in the rotating pump. An optional open saddle interlock can be supplied with Verderflex[®] Smart-F pumps to stop the pump whenever the saddle is opened.
- Use suitable connectors between the tube and both the suction and the discharge pipework. Select fittings according to the required pressure rating, chemical compatibility and temperature stability. The correct tube material, tube diameter and suction / discharge pipe diameter must be

selected. If the diameter of the tube or pipes is too small it may cause excessive pressure and is therefore not recommended.

3.3 Maintenance and Repair

⚠ WARNING

- Only experienced and authorised personnel may carry out maintenance and repair work on Verderflex[®] Smart-F tube pumps. If in doubt consult VERDER or your local Verderflex[®] distributor for advice.
- If dangerous or unknown materials have been used with the pump, it must be emptied and cleaned before maintenance and repairs are carried out.
- When the pump has been pumping a hazardous or unknown material, it is mandatory to wear appropriate personal protective equipment, including but not limited to protective glasses, protective gloves, etc whilst working in the proximity of the pump. These items should be specified by the user taking account of the chemical(s), working environment & local, regional & national safety requirements.
- As with any peristaltic pump, you should always consider the tube's lifetime and ensure that you change the tube at the end of a suitable period of operation. Failure to change the tube within good time may result in accidents and injury to personnel.

⚠ DANGER

- The voltage contained within the pumps motor casing should be considered dangerous!
- Before you open the pump casing, the pump must be switched off and isolated at a suitably installed switch. During maintenance or repair service, you must ensure that no unauthorized personnel can switch the pump on.
- Only de-contaminated pumps can be returned to either VERDER or your local Verderflex[®] distributor.

3.4 Temperature during transport and operation

- If the pump was subjected to extreme temperature during transport, let the pump adjust to room temperature prior to start-up.
- The ambient temperature must be between 0°C and 40°C (32 and 104°F).

⚠ WARNING

- Most tube materials used during operation of the Verderflex[®] Smart-F pump have a maximum operating temperature in excess of 100 °C (212°F). However, we do not recommend the pumping of fluids with a temperature above 45 °C (113°F). If fluids are pumped at elevated temperature the operator should be aware that in the case of tube failure, hot fluids could egress. Suitable safety equipment such as safety screens must be in place.

4 The Pump Head

4.1 Description of the Pump Head

The pump head comprises four parts:

- The rotor with rollers which are responsible for the peristaltic action of the pump
- The transparent front cover, which allows the operator to check the pump operation and the direction of rotation.
- The lower section, which houses the V-shaped tube clamps. The tube clamps are spring loaded to self-adjust to any permitted tube size. The purpose of the clamps is to stop the tube from 'walking' to the discharge side. On the pressure side, the clamps are designed to self-centre the tube. The compression generated by the springs can be adjusted by turning two screws, one for each clamp. The screws are located in the clamp base.
- The tube saddle counteracts the compressive action of the rotor. The saddle can be removed by unlocking the 'ski-boot' style lever.

4.2 Optional Tube Saddle Status Detection SSD

- The tube saddle status detection interlocks the tube saddle and the pump. The tube saddle status detection comprises three components:
 - A reed switch embedded in the back plate of the pump head
 - A set of two magnets fitted to the tube saddle, one at either side. This means that it does not matter, which way round the saddle is fitted to the pump head.
- When connected to suitable circuitry the tube saddle status detection will detect if the tube saddle is fitted properly and will either:
 - Not allow the pump to be started or,
 - Stop the pump immediately if the saddle is opened while the pump is running.

4.3 Changing and Cleaning the Pump Head



The tube clamps are spring loaded. Wear safety goggles when removing, disassembling or reassembling the pump head!

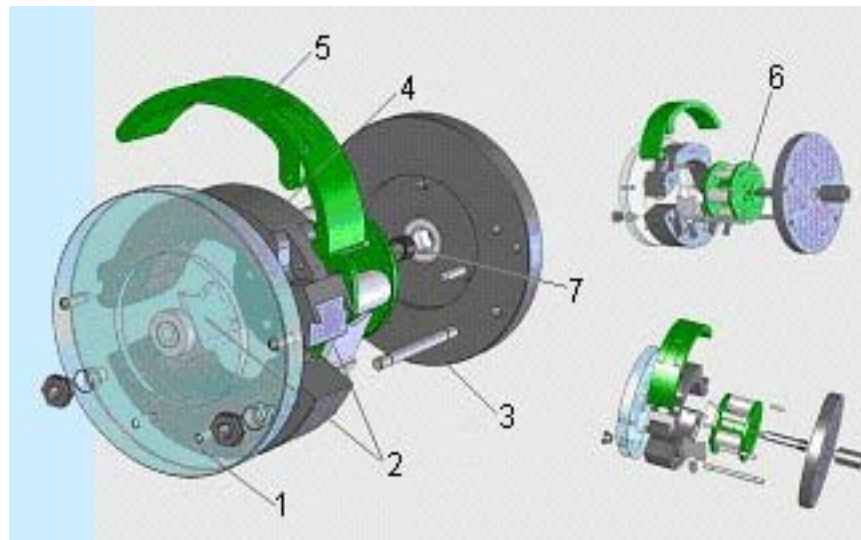

ITEM NUMBER	DESCRIPTION
1	Front cover
2	Tube clamps
3	Back plate
4	Saddle
5	Lever and claw lock
6	Rotor
7	Drive coupling bush

All the pump heads for the Verderflex[®] Smart-F pump are of the same design principle and are easy to disassemble:

- Open the 'ski-boot' style lever and slide the claw off the dowels.
- Remove the saddle and the tube (if fitted).
- Remove the two locking nuts on the transparent front cover.
- Remove the front cover.
- Slide the rotor off the shaft.
- Remove the hexagonal drive shaft.
- Slide the lower section off the two mounting pins.
- Carefully remove the tube clamps from the lower section, taking care not to lose the springs.
- This now leaves the back plate attached to the pump casing. To remove the plate, undo the three fixing bolts then slide the plate off the drive shaft, which protrudes out of the pump casing. Take care not to lose the bush connecting the drive shaft to the pump head.
- The pump head components can be cleaned in warm water using a mild detergent. Do not use abrasive cleaners as this may scratch the parts, which may adversely affect the pump performance.
- In order to re-assemble the pump head, follow the above instructions in reverse order.

For correct installation of the Front Cover the locking nuts should tighten to 3Nm for the S10 and S20, and 5Nm for the S30 and S40.

Please note:

- Inspect the connecting bush in the back plate for signs of wear and replace this part if necessary. If in any doubt, please contact either VERDER or your local Verderflex[®] distributor.
- To insert the tube clamps, push the clamps with the spring attached into the lower pump head section, leaving the loose end of the spring pointing upwards. Then push the loose end into the holder. This way you can ensure that the spring is correctly centred. Take care that the angled side of the tube clamps point towards the inside of pump head. If the angled side points outwards the tube will not be properly fixed.
- Turn the screw on the adjustable clamps, until the end is well inside the metal clamp base. Insert the clamp and spring as explained above. Finally turn the screw until the end re-appears.



1. Spring-loaded tube clamps. The picture shows a base with adjustable springs
2. Horizontal bore to thread cable from Reed switches through.
3. Recessed screws to adjust the tension of the tube clamps

4.4 Installing a multi-channel pump head

- Installing a multi-channel pump head is very similar to the procedure outlined above. However, please note:
- Each channel is fitted with its own saddle status detector. If this is to be installed the wires should be threaded through the horizontal bore of each lower pump head section (see (2) in the picture above), pointing towards the pump casing.
- Connect the wires in series to the cable leading to the safety board, behind the back plate, which is bolted to the pump casing,
- Finally stack up the individual components on the tie bars and drive shaft to assemble the multi pump head.

**⚠ WARNING**

- If the optional sensors are not wired in series, i.e. if they are wired in parallel, then the pump will not stop if the saddle of an individual channel is opened. The operator is then exposed to moving parts. If in any doubt consult a fully qualified electrician. Failure to wire up the saddle status detection correctly will also invalidate the warranty offered by VERDER.

4.5 Changing the tube**Insert the tube****Insert the saddle****Locking the saddle**

- To insert a tube, open the 'ski-boot' style lever and take the claw section off the dowels fitted to the front cover and the back plate. Now remove the saddle from the pump head.
- Insert the tube and ensure that the tube is roughly centred within the pump head.
- Fit the saddle to one set of dowels, open up the lever and fit the claw over the other set of dowels
- Push the lever down to lock the saddle into place.
- Please note that it does not matter whether the claw is on the left or right hand side of the pump head.

Check whether the tube walks through the pump head. If it does, tighten up the adjustable tube clamps **ON THE SUCTION SIDE**, by turning the screw clockwise until the tube remains stationary. Take care not to over tighten the clamp, as this will reduce the flow generated by the pump. On the other hand, if does not walk at all, try and reduce the tension by turning the screw anti-clockwise. The tube clamp on the discharge side should always be retracted as far as possible.

5 Assembly of the Verderflex[®] Smart-F pump

The major components of a Verderflex[®] Smart-F pump are:

- Pumphead
- Mounting Flange
- Mounting Frame
- Motor and gearbox

A typical Verderflex[®] Smart-F will require a running torque of approximately 4 Nm per channel. The Verderflex[®] Smart-F series uses an industrial gearbox with a final speed of up to 240rpm and usually this has an integral motor of 0.25kW or 1/3 HP. Please note that due to two internal bearings in the pumphead, no radial loads need to be considered. The standard gearbox output shaft diameter is 20 mm, with a shaft length of 40 mm. The PCD of the gearbox bolts should be between 90 and 100 mm. Align the key into the keyway of the coupling and the gearbox shaft.

Push the keyway to hex coupling onto the gearbox output shaft.



Note the 'Top' mark, which must be on the upper side of the flange to ensure that the pumphead is mounted the correct way round.

Bolt the mounting frame to the mounting flange using the 4 tapped holes.

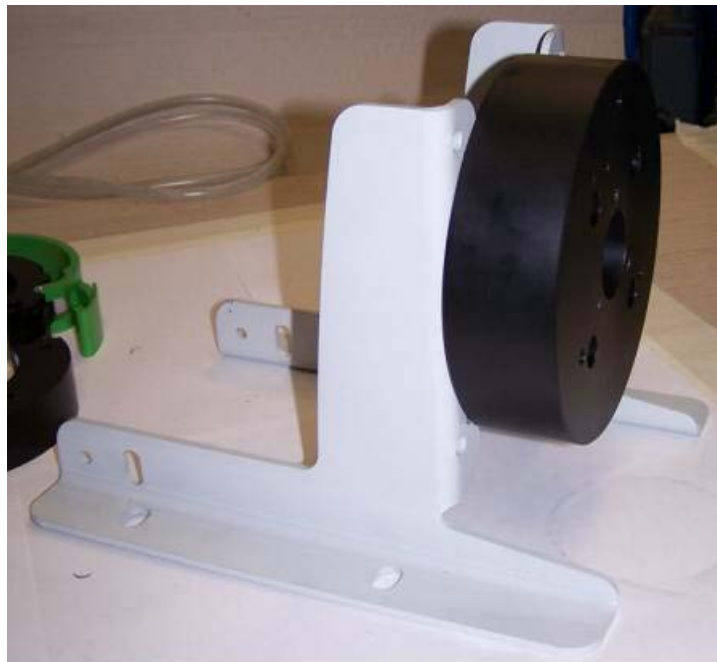

Mount and secure the gearbox using the four slotted holes. The gearbox must be mounted from the mounting frame side.



Next, fit the pumphead following the instruction given above. The three outer tapped holes are for the S30 & S40 heads, whilst the inner tapped holes are for the S20 heads.

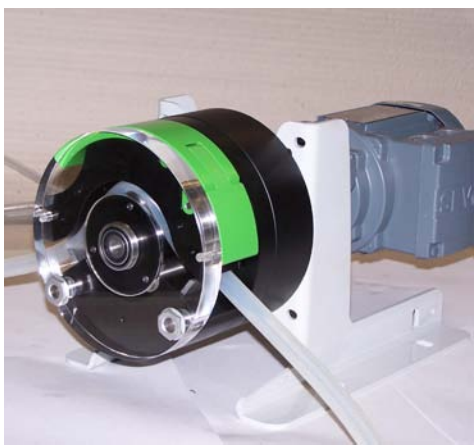
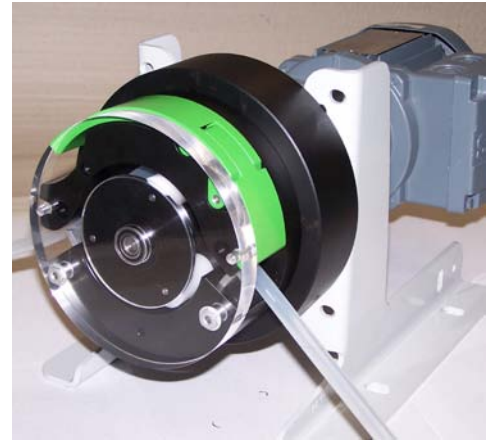
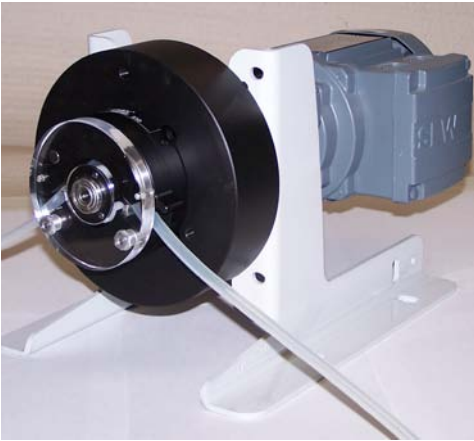

5.1 Use of the Smart F-Series with Inverters & SCADA Systems

The Verderflex® Smart F-Series pump uses an industry standard gearbox & motor and as such can be easily controlled by either a motor mounted or stand alone inverter or variable frequency drive (VFD).

Similarly, the Verderflex® Smart F-Series can be readily interfaced with external control systems such as 4-20mA current loops, distributed control systems (DCS) or supervisory control systems (SCADA) with different communication protocols including MODBUS®, PROFIBUS® etc by means of optional communication modules fitted into the inverter.

Such devices should be installed in accordance with their manufacturer's instructions.

6 Tube Selection and Operation Parameters

For pump curves and flow correction charts please refer to appendix 1

Guidelines to select a suitable tube:

PUMP HEAD SIZE	MINIMUM INNER DIAMETER	MAXIMUM INNER DIAMETER	WALL THICKNESS
S20	1.6 mm (1/16 ")	8.0 (5/16 ")	1.6 or 2.4 mm (1/16 or 3/32 ")
S30	6.4 (1/4 ")	15.9 (5/8 ")	3.2 mm (1/8 ")
S40	9.6 mm (1/3 ")	25.4 mm (1 ")	3.2 or 4.8 mm (1/8 or 3/16 ")

Please note that the S20 and S40 pump heads are by default, supplied with saddles for 2.4 mm and 4.8mm wall thickness respectively. If the S20 and S40 heads are operated with smaller wall thickness tubes (i.e. 1.6 mm or 3.2 mm respectively) then the pump will not generate any suction lift or discharge pressure. For proper operation a separate saddle is required.

If saddles for 1.6mm / 3.2mm wall thickness tubing are used with 2.4mm / 4.8 mm wall thickness tubes this will lead to shortened tube life.

6.1 Chemical Compatibility Testing

Data for a wide range of tube materials are available on [.verderflex.com](http://verderflex.com)

In case of unknown chemical compatibility of the tube and the product being pumped a soaking test should be carried out. This can be achieved using the following method:

- Cut a sample of tubing and measure it's length and wall thickness
- Leave a piece of the tube submersed in the fluid in question for a week.
- Assess the dimensions of the test pieces: Swelling (increased size and/or thickness) and softening / hardening indicate that the tube material is not suitable for this application.

Ideally this test should be done at elevated temperature, as this will speed up any chemical reaction between the tube material and the fluids. For advice on appropriate tube materials contact either Verderflex[®] or your local Verder distributor.

Verderprene and platinum cured Silicone tubes have very good fatigue life, but are limited in their chemical compatibility. However fluorinated materials, such as Viton[®] or Fluran[®] might have better chemical resistance but are limited by their fatigue life.

- To avoid a loss of flow, keep the suction line and pressure line as short as possible. Rigid suction and discharge lines should, where possible, be straight without any fittings or elbows and should be over-sized relative to the tube size being used.
- For a longer tube life, operate the pump at low speed and with large inner tube diameters.
- Pumping or dosing of viscous fluids is best done at low speeds using a large bore tube. Please note that an inner diameter / wall thickness ratio > 4 may lead to reduced performance.
- When pumping fluids with a solid content, please bear in mind that narrow bore tubes are likely to block.
- Most tube materials have a maximum operating temperature in excess 100°C (212°F).

⚠ WARNING

- When pumping fluids at high temperature, the operator should be protected from any hot fluids which may escape at fittings or bursts.

Fluran[®] is a registered trademark of Saint-Gobain Performance Plastics
Viton[®] is a registered trademark of DuPont Dow Elastomers

6.2 Reducing Pulsation

As with any positive displacement pump, the Verderflex[®] Smart-F pump will generate pulsation. While this is not an issue for general transfer applications, pulsation may reduce the accuracy of the pump in dosing or batching applications or affect fragile/highly shear sensitive products such as those used in the biotechnology industry. Verderflex[®] offers two solutions that will reduce, pulsation:

6.2.1 Use of a six-roller rotor

- A six-roller rotor will generate higher frequency pulsation. As pulses then partially overlap, the overall amplitude of pulsation will be greatly reduced. Please note that the use of six-rollers will reduce the flow by approximately 30% as compared to the three-roller head using the same sized tube and pump speed.

6.2.2 Use of two-channel pump head

- Assuming that the rotors in the two channels are staggered, as shown in the drawing below, and that the flow is split in front and merged past the pump head, pulses will overlap and cancel each other out. This option can also be selected if a large flow is required.

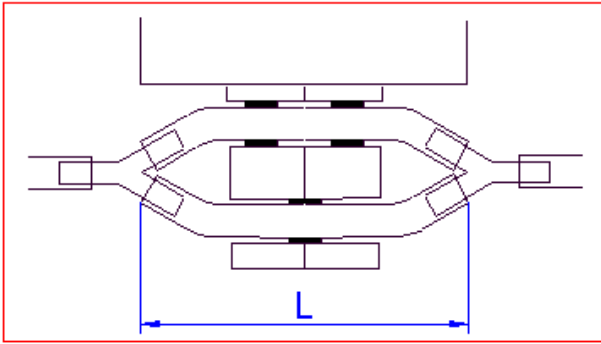

View of the pump head from above
(without the tube saddle):

Please note that the length of tube
passing through both pump heads must
be the same [L].

- We recommend that only Y-pieces can be used to split and merge the fluid stream.

7 Pump Curves

Pump Curves have been determined under ideal laboratory conditions in our test facilities using Verderprene tubes. The flow generated is affected by a number of parameters, for example the nature of the fluid, suction conditions, discharge conditions etc. In many cases the actual flow produced within a system will be lower than the flow shown here.

7.1 FREE FLOW CURVES

The Free Flow Curves cover the standard tube saddles and tube sizes; curves for other sizes can be made available on request.

Free Flow Pump Curve

Verderflex[®] Smart-F S20 Head 2.4mm Walled Tube

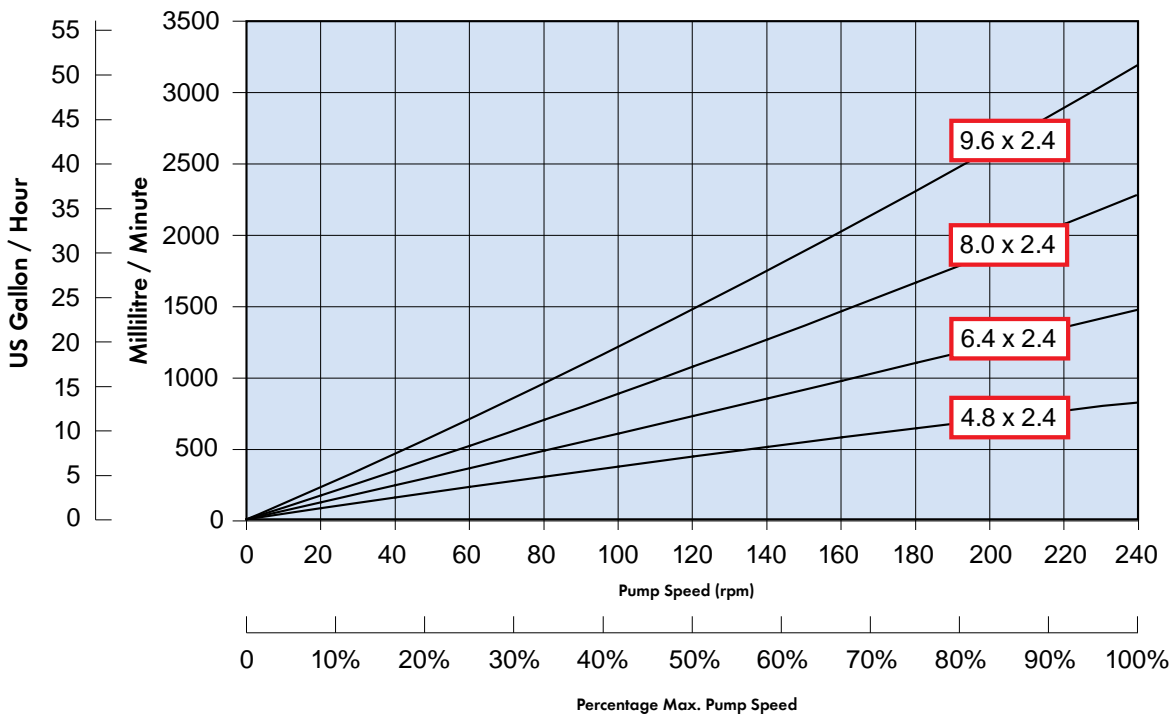

Free Flow Pump Curve
Verderflex[®] Smart-F S30 Head 3.2mm Walled Tube

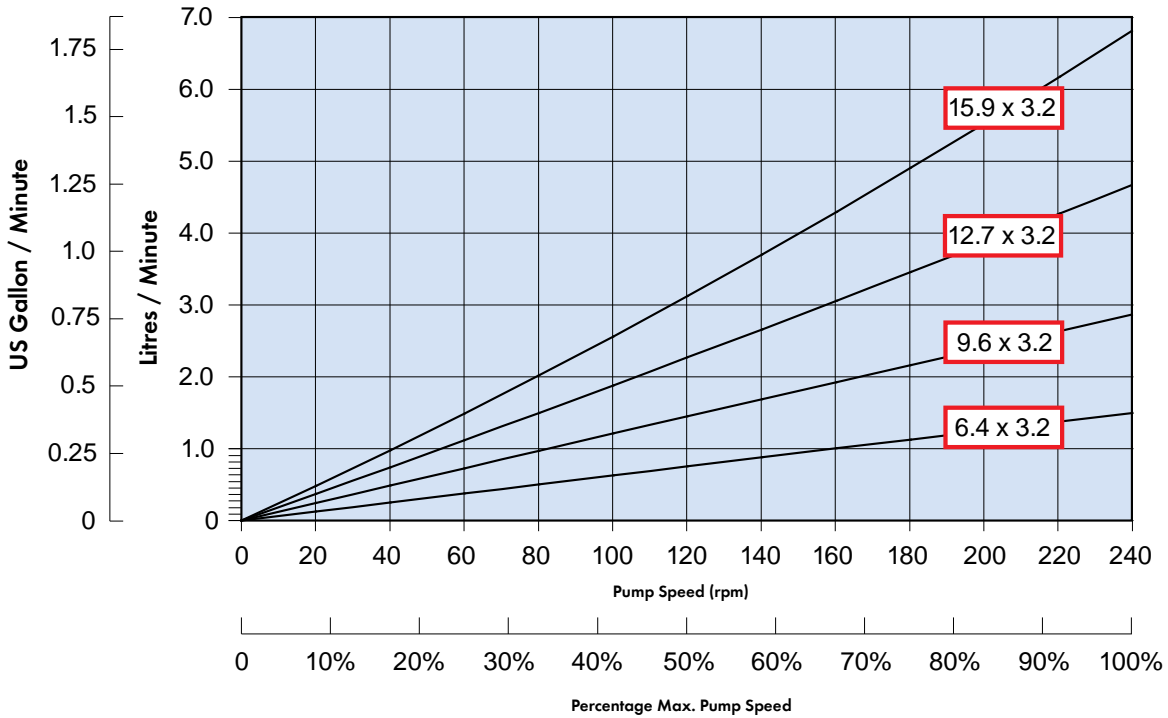

Free Flow Pump Curve
Verderflex[®] Smart-F S40 Head 4.8mm Walled Tube

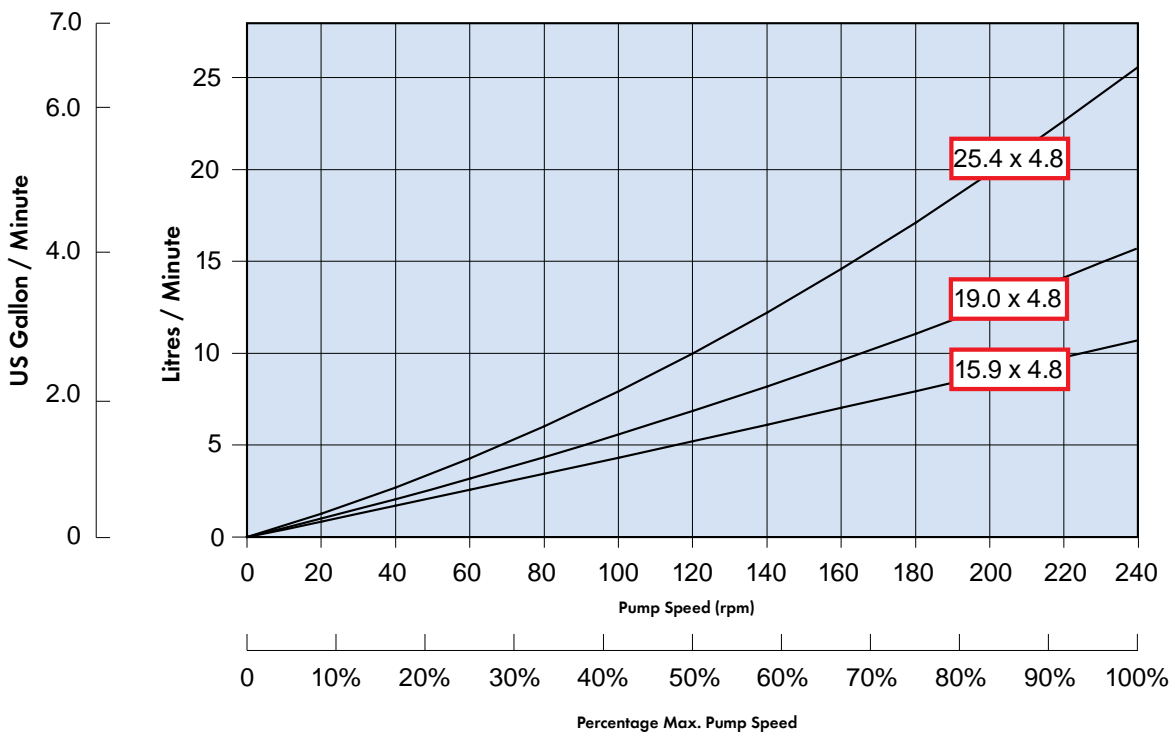

7.2 SUCTION CORRECTION CURVES

Tested Methodology

The suction head loss correction curves were determined by pumping water out of a partially evacuated pressure tank. -0.5-bar pressure (50% vacuum) is the same as the pump lifting water 5 m into the pump. Data was collected at a pump speed of 240 rpm. The pump speed does not affect the suction performance of the pump.

The curves are presented with the suction pressure and lift (in mWc & ftWc) on the x-axis and the percentage nominal flow on the y-axis. For example, on the S20 head, a 6.4*2.4 Verderprene tube, lifting water 4 metres (-0.4 bar), would generate approximately 93% of it's free-flow predicated flow as compared to the nominal capacity under free flow condition. It is therefore recommended to speed up the pump by approximately 7% to compensate for the losses.

S20 Suction Loss Curves for 2.4mm walled tubes

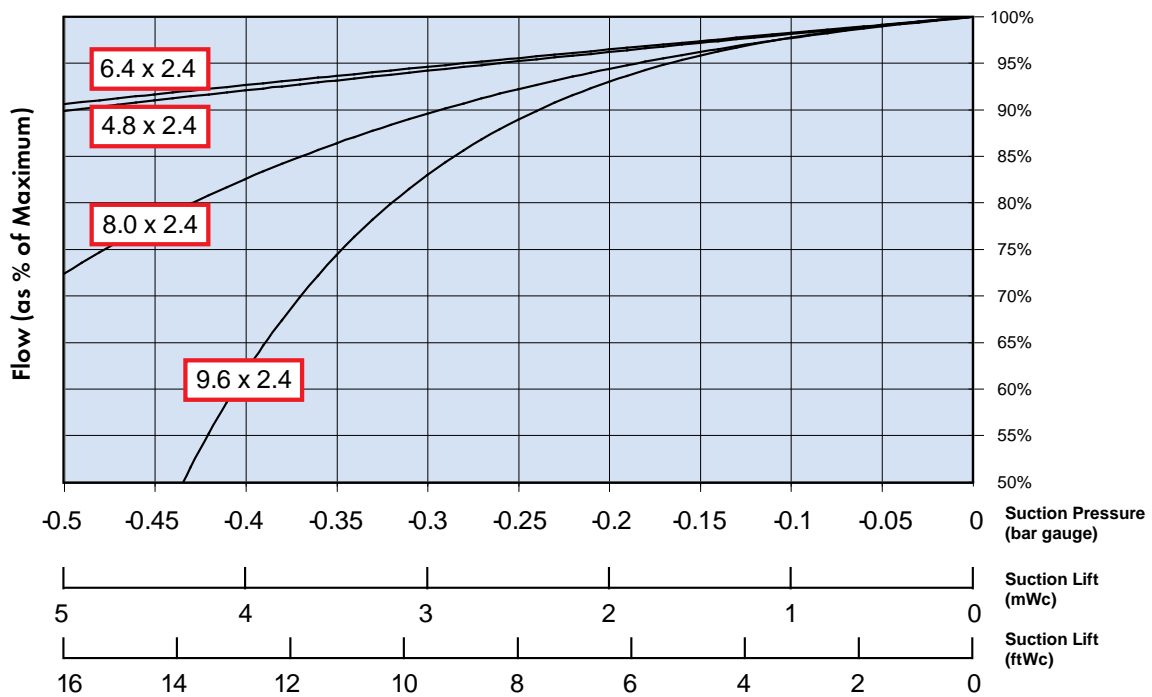

S30 Suction Loss Curves for 3.2mm walled tubes

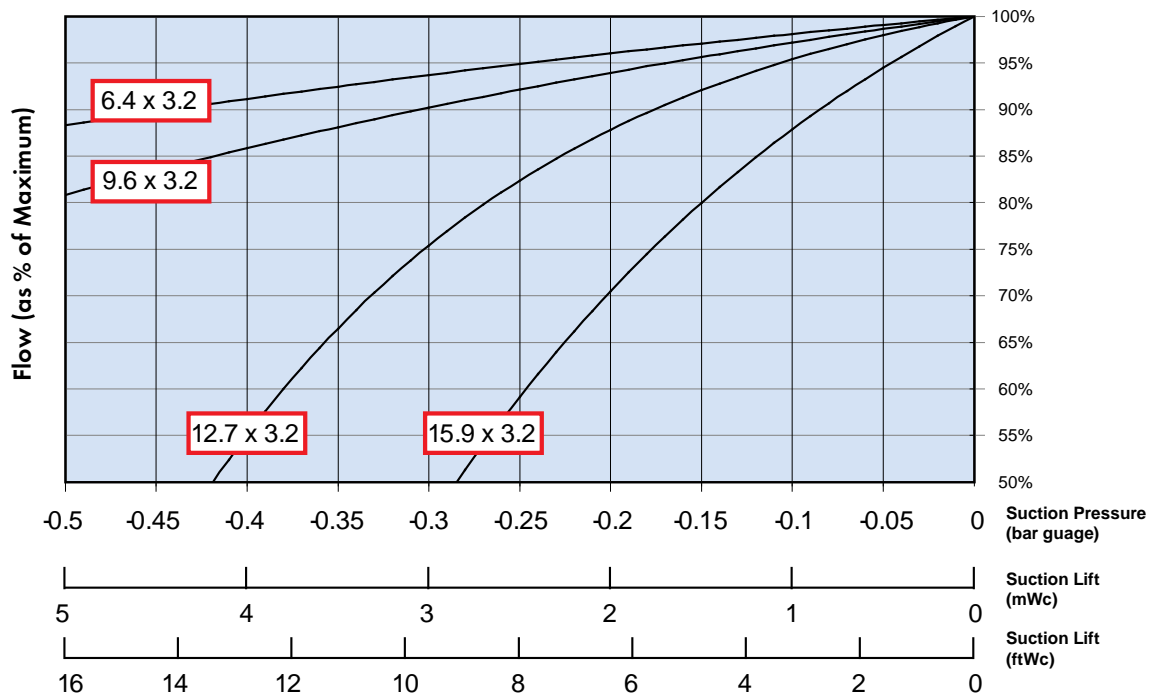

S40 Suction Loss Curves for 4.8mm walled tubes

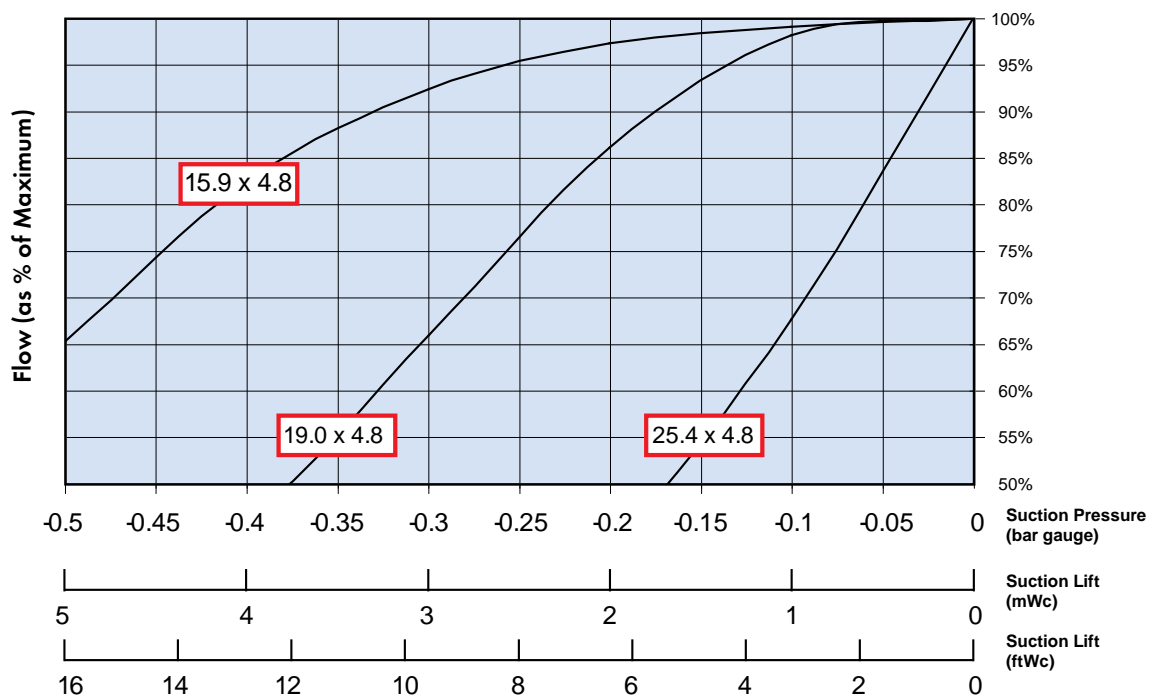

7.3 Discharge Pressure Limitation

Tested Methodology

Water was pumped into a pressurised tank to determine the pump performance against discharge pressure. Tests showed that up to a critical pressure the flow only depends on the pump speed, not the discharge pressure, and no correction needs to be applied.

Beyond this critical pressure, the flow rapidly drops. The table below gives the tube dimension, ratio of inner diameter / wall thickness, the critical pressure and a maximum recommended working pressure for Verderprene. The maximum working pressure is defined as ¼ of the burst pressure.



During our tests we routinely worked at pressures in excess of the recommended pressure. However, when working above the recommended pressure, the user must be aware that the tube's elastic limit (the point where the material changes from elastic to inelastic deformation) is not well defined. Therefore there is no way to predict when the material will overstretch and how far it will overstretch without a burst! Once overstretched, the tube will not recover and must be disposed off.

PUMP HEAD	WALL THICKNESS	TUBE DIAMETER	ID / WALL RATIO	CRITICAL PRESSURE / bar	MAX. WORKING PRESSURE / bar
S20	1.6	3.2	2	<<<<1	1.8
S20	2.4	4.8	2	<<<<1	1.4
S20	2.4	6.4	2.67	<1	1.4
S20	2.4	8.0	3.33	~1.25	1.2
S20	2.4	9.6	4	~1.75	1.1
S30	3.2	6.4	2	<<<1	1.8
S30	3.2	9.6	3	<<<1	1.3
S30	3.2	12.7	4	~1	1.1
S30	3.2	15.9	5	~1.75	0.9
S40	4.8	15.9	3.33	1.1	1.2
S40	4.8	19.0	4	1.1	1.1
S40	4.8	25.4	5.33	1.5	0.8

Shaded rows indicate tube dimensions, which have very low discharge pressure. When discharge head is an important consideration then we advise the user to select tubes one or two sizes up and adjust the pump speed accordingly.

When comparing the discharge and suction performance it becomes clear that the tube that provides good suction (low ratio of inner diameter / wall thickness) is poor for discharge pressure (critical pressure very low).

Higher discharge pressure of up to 75 bar / 100 PSI can be achieved using specially adapted pump heads and a special higher pressure tubing. Any interested customers are invited to contact VERDER or the local Verderflex distributor.

All performance and flow correction charts were determined under ideal laboratory conditions with reference line sizes. Actual performance may vary due to the installation and should be determined for each pumping situation.

VERDER does not assume any responsibility or liability for any advice furnished by it, or for the performance or results of any installation or use of the tubes or of any final product into which the tube may be incorporated.

It is the user's responsibility to ensure the suitability and safety of tube materials for all intended uses. Further test must be conducted in accordance with applicable requirements in order to determine the safety and effectiveness for use of the tube selected in any particular application.

8 Fault Finding

PROBLEM	CAUSE	SOLUTION
Low Flow / low discharge pressure	Ratio of inner diameter / wall thickness too large for the application (tube too 'soft')	Use thicker wall thickness tube with the same inner diameter. This may require a different saddle!
		Run Pump slower with larger inner diameter tube
	Viscosity too high	Use a bigger tube or run the pump slower
	Suction lift too high, resulting in tube not fully returning to fully round	Use thicker wall thickness tube with the same inner diameter. This may require a different saddle!
		Use a bigger pump running slower
	Wall thickness does not match the specifications of the saddle used.	Purchase appropriate saddle or change wall thickness
Discharge pressure too high	Poor flow is caused by excessive backflow, reduce discharge pressure	
Tube walks through pump head	Tube outer diameter too small for the pump head used	Use tube with correct outer diameter.
	Adjust tube clamp tension	See section 4.5 for advice

9 Spare Parts

No. on Diagram	HEAD TYPE	SUPPLIED AS	DESCRIPTION	PART NO.
	S20	Kit	Foot Assembly Kit for S20 Pumps	179.9000
1	S20	Each	S20 Head Front Cover Assy incl Bearing	179.2100
2	S20	Each	S20 3 Roller & Rotor Assembly Complete	179.2200
3	S20	Kit	S20 3 Roller Assembly Kit	179.2300
4	S20	Each	S20 Clamping Assembly	179.2400
5	S20	Each	S20 Saddle 2.4mm WT 3 Roller - no lever	179.0017
6	S20	Each	S20 Lever Assy	179.2600
7	S20	Each	S20 Saddle Assy 2.4 mm WT 3 Roller c/with Lever	179.0086
8	S20	Each	S20 1 ch Shaft	179.2700
5	S20	Each	S20 Saddle 1.6mm WT 3 Roller - no lever	179.0044
7	S20	Each	S20 Saddle Assy 1.6 mm WT 3 Roller c/with Lever	179.0087
2	S20	Each	S20 6 Roller & Rotor Assembly Complete	179.2800
3	S20	Kit	S20 6 Roller Assembly Kit	179.2301
5	S20	Each	S20 Saddle 2.4 mm WT 6 Roller - no lever	179.2501
7	S20	Each	S20 Saddle Assy 2.4 mm WT 6 Roller c/with Lever	179.2502
5	S20	Each	S20 Saddle 1.6 mm WT 6 Roller - no lever	179.2511
7	S20	Each	S20 Saddle Assy 1.6 mm WT 3 Roller c/with Lever	179.2587
	S30	Kit	Foot Assembly Kit for S40 Pumps	179.9001
1	S30	Each	S30 Head Front Cover Assy incl Bearing	179.3100
2	S30	Each	S30 3 Roller & Rotor Assembly Complete	179.3200
3	S30	Kit	S30 3 Roller Assembly Kit	179.3300
4	S30	Each	S30 Clamping Assembly	179.3400
5	S30	Each	S30 Saddle 3.2mm WT 3 Roller - no lever	179.0084
6	S30	Each	S30 Lever Assy	179.3600
7	S30	Each	S30 Saddle Assy 3.2 mm WT 3 Roller c/with Lever	179.0059
8	S30	Each	S30 1 ch Shaft	179.3700
2	S30	Each	S30 6 Roller & Rotor Assembly Complete	179.3800
3	S30	Kit	S30 6 Roller Assembly Kit	179.3301
5	S30	Each	S30 Saddle 3.2 mm WT 6 Roller - no lever	179.3501
7	S30	Each	S30 Saddle Assy 3.2 mm WT 6 Roller c/with Lever	179.1059
	S30	Each	Transformer 330W -	173.0006
	S40	Kit	Foot Assembly Kit for S40 Pumps	179.9001
1	S40	Each	S40 Head Front Cover Assy incl Bearing	179.4100
2	S40	Each	S40 3 Roller & Rotor Assembly Complete	179.4200
3	S40	Kit	S40 3 Roller Assembly Kit	179.4300
4	S40	Each	S40 Clamping Assembly	179.4400
5	S40	Each	S40 Saddle 4.8mm WT 3 Roller - no lever	179.0016
6	S40	Each	S40 Lever Assy	179.4600
7	S40	Each	S40 Saddle Assy 4.8 mm WT 3 Roller c/with Lever	179.0105
8	S40	Each	S40 1 ch Shaft	179.4700
5	S40	Each	S40 Saddle 3.2 mm WT 3 Roller - no lever	179.4502
7	S40	Each	S40 Saddle Assy 3.2 mm WT 3 Roller c/with Lever	179.0095
2	S40	Each	S40 6 Roller & Rotor Assembly Complete	179.4800
3	S40	Kit	S40 6 Roller Assembly Kit	179.4301
5	S40	Each	S40 Saddle 4.8 mm WT 6 Roller - no lever	179.1016
7	S40	Each	S40 Saddle Assy 4.8 mm WT 6 Roller c/with Lever	179.1105
5	S40	Each	S40 Saddle 3.2 mm WT 6 Roller - no lever	179.4503
7	S40	Each	S40 Saddle Assy 3.2 mm WT 6 Roller c/with Lever	179.1095
	S40	Each	Transformer 330W -	173.0006

10 Warranty & Contact Details

Your Verder distributor should have completed a warranty card on your behalf, which is returned to VERDER for registration on the warranty scheme. Please ensure that the distributor has the following details from your initial and any subsequent orders for pump(s) and / or spares:

Pump / spares make and type
Serial number
Application
Fluid to be pumped
Pressure
Temperature
Capacity
Suction
Date of order and delivery
Verder reference

Full completion of this card is essential for you to be covered by VERDER warranty schemes. Please be aware of the declaration that you undertake to use only Verder spare parts including lubricant - this is an essential part of the warranty scheme and is legally binding. The card will also act as a record of your dealings with VERDER and its distributors.

This information will similarly be required if and when you should need to order spare parts from your local Verder distributor.

Should you have cause to return the pump for any reason, please ensure that you inform the local distributor as fully as possible of the details of the problem; the distributor has the necessary documentation for completion of the warranty application to VERDER and is aware that this has to be completed in full before VERDER can examine the application.

Complaints Procedure

VERDER takes its responsibilities to its customers extremely seriously and prides itself on its comprehensive complaint procedures. Should you be dissatisfied with your Verder pump(s) or with any aspect of the service you have received, then please contact your local Verder distributor in the first instance to discuss the matter fully.

The distributor will then take the matter up with Verder, acknowledging his actions to the customer and indicating a time scale by which he will reply. You will receive a response from the distributor with VERDER initial comments and proposed plan of any further action. If you feel that your complaint has still not been resolved satisfactorily, you should contact VERDER directly at the address given overleaf.

Verder Group Literature

Verder supplies its range of Group literature and product documentation in a number of languages and variety of software packages - please advise your Verder distributor if you are interested in receiving other information on Verder, indicating in which languages and format.

Verder and its distributors undertake to conduct all its dealings with you as comprehensively, courteously and promptly as possible. Customer care is one of Verder's top priorities

Distributor Contact Details:

Verder Contact Details:

VERDER
Whitehouse Street
Leeds LS10 1AD
ENGLAND, UK
Tel: (+44) 113 222 0250
Fax: (+44) 113 222 0291
E-mail: [@verderflex.com](mailto:)
Web Site: .verderflex.com

Warning Symbols

Signal words designate a degree or level of hazard seriousness. They are used in this manual in accordance with ANSI Z535.4-1991 and are defined as follows:



The symbol shown above is used to identify topics of primary safety concern and call attention to instructions concerning your personal safety. Look out for this symbol, it highlights important safety precautions, and means "ATTENTION! BE ALERT! YOUR PERSONAL SAFETY IS INVOLVED!" Read the message that follows and be alert to the possibility of personal injury.

 **DANGER**

Indicates an imminently hazardous situation, which, if not avoided will result in death or serious injury. This signal word is limited to most extreme situations

 **WARNING**

Indicates a potentially hazardous situation, which if not avoided could result in death or serious injury.

Trademarks

Some products mentioned in this manual or used in combination with Verderflex[®] Smart-F pumps are, or are asserted to be, proprietary names or trademarks. VERDER. acknowledges the rights of the respective owners of proprietary names and trademarks. Should trademarks not be indicated does not imply that they have acquired for legal purposes a non-proprietary status nor is any judgement implied concerning their legal status.

TABLE OF CONTENTS

DISCLAIMER OF WARRANTY AND LIMITATIONS OF LIABILITY	4
1. INTRODUCTION	6
2. THE VERDERFLEX® SMART-F PUMP	7
3. SAFETY ISSUES	8
3.1 General Safety Notes.....	8
3.2 Installation, Usage and Operation	8
3.3 Maintenance and Repair	9
3.4 Temperature during transport and operation	9
4. THE PUMP HEAD	10
4.1 Description of the Pump Head	10
4.2 Optional Tube Saddle Status Detection SSD.....	10
4.3 Changing and Cleaning the Pump Head	10
4.4 Installing a multi-channel pump head	12
4.5 Changing the tube	13
5. ASSEMBLY OF THE VERDERFLEX® SMART-F PUMP	14
6. TUBE SELECTION AND OPERATION PARAMETERS.....	16
6.1 Chemical Compatibility Testing	17
6.2 Reducing Pulsation	18
6.2.1 Use of a six-roller rotor	18
6.2.2 Use of two-channel pump head.....	18
7. PUMP CURVES	20
7.1 FREE FLOW CURVES.....	20
7.2 SUCTION CORRECTION CURVES	22
7.3 Discharge Pressure Limitation.....	24
8. FAULT FINDING	26
9. SPARE PARTS	27
10. WARRANTY & CONTACT DETAILS.....	29
COMPLAINTS PROCEDURE.....	29
VERDER GROUP LITERATURE.....	30
DISTRIBUTOR CONTACT DETAILS:.....	30
VERDER CONTACT DETAILS:	30

Disclaimer of Warranty and Limitations of Liability

This pump is warranted against defects in workmanship and material under normal use (rental pumps excluded) for two years from date of purchase. This is limited to the extent that Verder will at its option replace, repair or refund, in full, the purchase price of the instrument or any part thereof manufactured by VERDER, which in our opinion is defective. This is subject to the instrument having been operated in strict accordance with this manual, and having not been subjected to tampering, abuse or exposed to highly corrosive and/or unspecified explosive conditions.

This warranty does not cover the conditions arising as follows:

- Failure of VERDER manufactured parts or components including tube & rollers, due to normal wear or any damage or failure, that in VERDER's judgement, arises from misuse
- Failure to implement the necessary safety procedures for use in the European Community of a pump within an explosive atmosphere as laid down in latest EC Atex directive from 1st July 2003. The standard Verderflex[®] Smart-F[™] pump is not ATEX certified, please see further advice below
- Failure to disclose the (intended or unauthorized) use of a pump within a known explosive atmosphere

VERDER MAKES NO WARRANTIES, EXPRESSED OR IMPLIED, INCLUDING, WITHOUT LIMITATION, ANY WARRANTIES OF FITNESS OR MERCHANTABILITY, EXCEPT AS EXPRESSLY SET FORTH ABOVE. VERDER SHALL NOT BE LIABLE FOR ANY INJURIES, LOSSES OR DAMAGES INCLUDING, BUT NOT LIMITED TO ANY PERSONAL INJURIES, ANTICIPATED OR LOST PROFITS, INCIDENTAL DAMAGES, CONSEQUENTIAL DAMAGES, COSTS, TIME CHARGES, OR OTHER DAMAGES OR LOSSES, IN CONNECTION WITH THE INSTRUMENT, ITS USE OR ANY REPLACEMENT PARTS THEREOF.

Full completion of the warranty card is essential in order to be covered by VERDER's outstanding warranty schemes. Please be aware of the declaration that you undertake to use only Verderflex[®] spare parts - this is an essential part of the warranty scheme and is legally binding. The card will also act as a record of your dealings with VERDER and its distributors.

This warranty is voided if the customer fails to follow any and all instructions, warnings or cautions in this Verderflex[®] Smart-F Pump Safety, Operation and Maintenance Manual. VERDER has made every effort to illustrate and describe the product(s) in this manual. Such illustrations and descriptions are, however, for the sole purpose of identification and do not express or imply a warranty that the products are merchantable or fit for a particular purpose, or that the products will necessarily conform to the illustration or descriptions

If a manufacturing defect is found, VERDER will replace or repair the instrument or replace any defective part thereof without charge. However, VERDER's obligation hereunder does not include the cost of transportation of the instrument to VERDER or its return to the customer; these costs must be borne by the customer. VERDER assumes no responsibility for damage in transit any claims for such damage should be presented to the carrier by the purchaser. In addition, instead of replacing or repairing the instrument as aforesaid, VERDER may, at its sole option, take back the

defective instrument and reimburse the customer for the purchase price in full settlement of any and all potential claims related to the purchase or use of the Verderflex[®] Smart-F pump

⚠ DANGER

Peristaltic Tube Pumps are frequently used in medical applications. The Verderflex[®] Smart-F is not certified for such applications and **MUST NOT** be used wherever the pump is directly connected to a patient.

⚠ DANGER

The standard Verderflex[®] Smart-F pumps are **NOT** ATEX certified and must not be used in hazardous and / or an explosive atmosphere. We can however supply, to special order, ATEX compliant pumps manufactured from conductive materials which are certified to EEx IIG T4. In conjunction with an ATEX certified motor and gearbox, such a pump head can be assembled into an ATEX certified Verderflex[®] Smart-F pump. Such a pump would be suitable for operation in these hazardous environments, provided that the pumped fluids have a conductance of at least 50 pS/m.

Due to material conductivity limitations the Verderflex[®] F40 cannot be supplied to ATEX requirements.

1. Introduction

The Verder Group of companies have offices located in Austria, Belgium, China, Czech Republic, France, Germany, Hungary, Japan, Norway, Poland, Romania, Slovakia, South Africa, The Netherlands, United States and the United Kingdom. A network of worldwide distributors supports our products in other countries. A full list is available on .verderflex.com. The Verder Group's headquarters are in Holland.

VERDER in-house designers and application engineers have developed the Verderflex[®] Smart-F range of peristaltic tube pumps. Full product training and documentation is available. VERDER will not accept responsibility for any malfunction of the pump caused by a failure to follow these operating procedures. If operators do not read and understand this manual, they are not considered by VERDER to be qualified to assemble, install, operate or maintain this equipment. As pumps are an integral part of an overall process, it is essential for the successful completion of the total process for the pump to be working to its full potential, and for the operator to be fully conversant with the operating principles of the tube pump.

VERDER is accredited to both the ISO 9000:2000 quality & ISO 14001:2004 environmental quality standards.

It is VERDER policy to supply all of its documentation in a number of languages and software options. Your Verder distributor will be able to assist you with the options available.

VERDER recognizes its responsibilities to its customers around the world, and will always seek to meet or exceed their reasonable expectations. VERDER welcomes customer comments, feedback and input into the development of procedures and products. Should you have any issues, which you wish to comment on, please return your comments to your local Verder distributor who will then forward them to VERDER for further action.

The latest version of this manual, product updates & notifications can be found on our website at .verderflex.com.

2. The Verderflex[®] Smart-F Pump

Description

- The Verderflex[®] Smart-F pump is a peristaltic pump designed for laboratories and industrial applications.
- Like VERDER, Verderflex[®] and Verderflex[®] Dura industrial hose pumps, the Verderflex[®] Smart-F is suitable, within reason, for pumping viscous fluids, fluids with solid content and fluids that are prone to degassing. The pump can run dry for a prolonged period of time and is self-priming.
- The Verderflex[®] Smart-F range is a series of pumps with industrial gear motor units drive and optional inverter controls. Please contact Verderflex[®] or your local distributor for more information.



3 Safety Issues



3.1 General Safety Notes

- Follow all instructions in this Safety, Operation and Maintenance Manual. Store the Safety, Operation and Maintenance Manual close to the Verderflex[®] Smart-F Pump.
- The Health and Safety of people, the environment and the successful operation of the process is very much dependent upon the actions of the operator of the Verderflex[®] Smart-F Pump.
- The user must read this Safety, Operation and Maintenance Manual carefully before you start using the Verderflex[®] Smart-F Pump, in order to avoid errors or damage to the equipment. The Verderflex[®] Smart-F pump must only be installed and operated by fully trained personnel. Particular emphasis must be given to the connection of the pump to local electricity supplies and compliance with local, regional and national electrical installation guidelines. Only suitably qualified personnel may connect or disconnect Verderflex[®] Smart-F Pump from such supplies. This should only be done under secure conditions. (i.e. The pump should be switched off, isolated and disconnected from the mains.)
- Only permitted accessories and approved original replacement parts may be used. The use of other parts can lead to unknown risks, which should be avoided at all times. The efficiency and safety of the Verderflex[®] Smart-F pump is only guaranteed when the required checks, maintenance, and repairs are carried out by a Verder Service Engineer or by personnel authorized by Verder.
- For queries and spare part orders include the product label information (in particular the pump serial number) as this enables us to supply the correct items.
- The sale, construction, installation, and/or use of Verderflex[®] Smart-F pumps may be governed by local legislation and / or standards. Although VERDER attempts to ensure that all our products fulfil all major international standards such fulfilment cannot be guaranteed. In addition we assume no liability regarding the use, installation and operation of Verder products. Before purchasing or using these units, please obtain information concerning the relevant local regulations.

3.2 Installation, Usage and Operation

- The Verderflex[®] Smart-F pump must be turned on & off by a suitably installed mains isolation switch when inserting the tubes or whilst cleaning the pump.
- Under no circumstances must the operator interfere any the interlock system that may be fitted as this may protect the user from exposure to moving parts. Please note that the unguarded pump rotor can cause injuries. DO NOT place any body parts in the rotating pump. An optional open saddle interlock can be supplied with Verderflex[®] Smart-F pumps to stop the pump whenever the saddle is opened.
- Use suitable connectors between the tube and both the suction and the discharge pipework. Select fittings according to the required pressure rating, chemical compatibility and temperature stability. The correct tube material, tube diameter and suction / discharge pipe diameter must be

selected. If the diameter of the tube or pipes is too small it may cause excessive pressure and is therefore not recommended.

3.3 Maintenance and Repair

⚠ WARNING

- Only experienced and authorised personnel may carry out maintenance and repair work on Verderflex® Smart-F tube pumps. If in doubt consult VERDER or your local Verderflex® distributor for advice.
- If dangerous or unknown materials have been used with the pump, it must be emptied and cleaned before maintenance and repairs are carried out.
- When the pump has been pumping a hazardous or unknown material, it is mandatory to wear appropriate personal protective equipment, including but not limited to protective glasses, protective gloves, etc whilst working in the proximity of the pump. These items should be specified by the user taking account of the chemical(s), working environment & local, regional & national safety requirements.
- As with any peristaltic pump, you should always consider the tube's lifetime and ensure that you change the tube at the end of a suitable period of operation. Failure to change the tube within good time may result in accidents and injury to personnel.

⚠ DANGER

- The voltage contained within the pumps motor casing should be considered dangerous!
- Before you open the pump casing, the pump must be switched off and isolated at a suitably installed switch. During maintenance or repair service, you must ensure that no unauthorized personnel can switch the pump on.
- Only de-contaminated pumps can be returned to either VERDER or your local Verderflex® distributor.

3.4 Temperature during transport and operation

- If the pump was subjected to extreme temperature during transport, let the pump adjust to room temperature prior to start-up.
- The ambient temperature must be between 0°C and 40°C (32 and 104°F).

⚠ WARNING

- Most tube materials used during operation of the Verderflex® Smart-F pump have a maximum operating temperature in excess of 100 °C (212°F). However, we do not recommend the pumping of fluids with a temperature above 45 °C (113°F). If fluids are pumped at elevated temperature the operator should be aware that in the case of tube failure, hot fluids could egress. Suitable safety equipment such as safety screens must be in place.

4 The Pump Head

4.1 Description of the Pump Head

The pump head comprises four parts:

- The rotor with rollers which are responsible for the peristaltic action of the pump
- The transparent front cover, which allows the operator to check the pump operation and the direction of rotation.
- The lower section, which houses the V-shaped tube clamps. The tube clamps are spring loaded to self-adjust to any permitted tube size. The purpose of the clamps is to stop the tube from 'walking' to the discharge side. On the pressure side, the clamps are designed to self-centre the tube. The compression generated by the springs can be adjusted by turning two screws, one for each clamp. The screws are located in the clamp base.
- The tube saddle counteracts the compressive action of the rotor. The saddle can be removed by unlocking the 'ski-boot' style lever.

4.2 Optional Tube Saddle Status Detection SSD

- The tube saddle status detection interlocks the tube saddle and the pump. The tube saddle status detection comprises three components:
 - A reed switch embedded in the back plate of the pump head
 - A set of two magnets fitted to the tube saddle, one at either side. This means that it does not matter, which way round the saddle is fitted to the pump head.
- When connected to suitable circuitry the tube saddle status detection will detect if the tube saddle is fitted properly and will either:
 - Not allow the pump to be started or,
 - Stop the pump immediately if the saddle is opened while the pump is running.

4.3 Changing and Cleaning the Pump Head



The tube clamps are spring loaded. Wear safety goggles when removing, disassembling or reassembling the pump head!

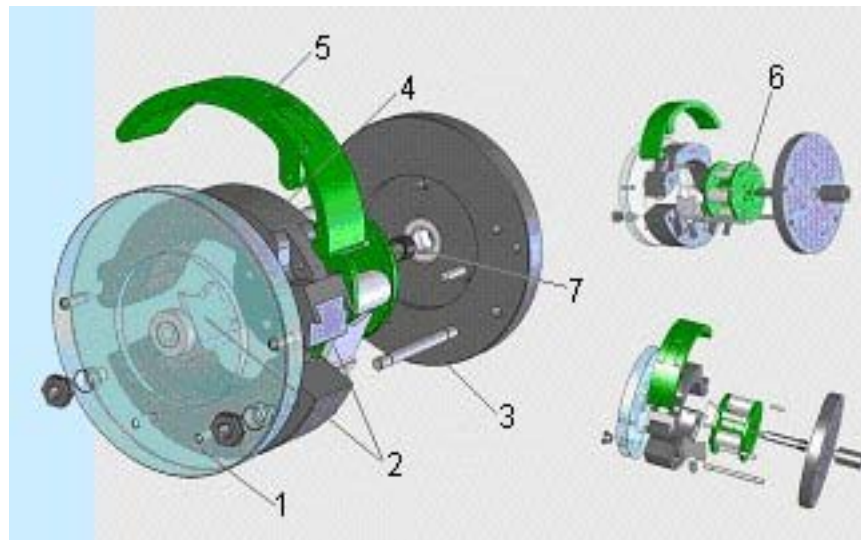

ITEM NUMBER	DESCRIPTION
1	Front cover
2	Tube clamps
3	Back plate
4	Saddle
5	Lever and claw lock
6	Rotor
7	Drive coupling bush

All the pump heads for the Verderflex[®] Smart-F pump are of the same design principle and are easy to disassemble:

- Open the 'ski-boot' style lever and slide the claw off the dowels.
- Remove the saddle and the tube (if fitted).
- Remove the two locking nuts on the transparent front cover.
- Remove the front cover.
- Slide the rotor off the shaft.
- Remove the hexagonal drive shaft.
- Slide the lower section off the two mounting pins.
- Carefully remove the tube clamps from the lower section, taking care not to lose the springs.
- This now leaves the back plate attached to the pump casing. To remove the plate, undo the three fixing bolts then slide the plate off the drive shaft, which protrudes out of the pump casing. Take care not to lose the bush connecting the drive shaft to the pump head.
- The pump head components can be cleaned in warm water using a mild detergent. Do not use abrasive cleaners as this may scratch the parts, which may adversely affect the pump performance.
- In order to re-assemble the pump head, follow the above instructions in reverse order.

For correct installation of the Front Cover the locking nuts should tighten to 3Nm for the S10 and S20, and 5Nm for the S30 and S40.

Please note:

- Inspect the connecting bush in the back plate for signs of wear and replace this part if necessary. If in any doubt, please contact either VERDER or your local Verderflex[®] distributor.
- To insert the tube clamps, push the clamps with the spring attached into the lower pump head section, leaving the loose end of the spring pointing upwards. Then push the loose end into the holder. This way you can ensure that the spring is correctly centred. Take care that the angled side of the tube clamps point towards the inside of pump head. If the angled side points outwards the tube will not be properly fixed.
- Turn the screw on the adjustable clamps, until the end is well inside the metal clamp base. Insert the clamp and spring as explained above. Finally turn the screw until the end re-appears.



1. Spring-loaded tube clamps. The picture shows a base with adjustable springs
2. Horizontal bore to thread cable from Reed switches through.
3. Recessed screws to adjust the tension of the tube clamps

4.4 Installing a multi-channel pump head

- Installing a multi-channel pump head is very similar to the procedure outlined above. However, please note:
- Each channel is fitted with its own saddle status detector. If this is to be installed the wires should be threaded through the horizontal bore of each lower pump head section (see (2) in the picture above), pointing towards the pump casing.
- Connect the wires in series to the cable leading to the safety board, behind the back plate, which is bolted to the pump casing,
- Finally stack up the individual components on the tie bars and drive shaft to assemble the multi pump head.

**⚠ WARNING**

- If the optional sensors are not wired in series, i.e. if they are wired in parallel, then the pump will not stop if the saddle of an individual channel is opened. The operator is then exposed to moving parts. If in any doubt consult a fully qualified electrician. Failure to wire up the saddle status detection correctly will also invalidate the warranty offered by VERDER.

4.5 Changing the tube**Insert the tube****Insert the saddle****Locking the saddle**

- To insert a tube, open the 'ski-boot' style lever and take the claw section off the dowels fitted to the front cover and the back plate. Now remove the saddle from the pump head.
- Insert the tube and ensure that the tube is roughly centred within the pump head.
- Fit the saddle to one set of dowels, open up the lever and fit the claw over the other set of dowels
- Push the lever down to lock the saddle into place.
- Please note that it does not matter whether the claw is on the left or right hand side of the pump head.

Check whether the tube walks through the pump head. If it does, tighten up the adjustable tube clamps **ON THE SUCTION SIDE**, by turning the screw clockwise until the tube remains stationary. Take care not to over tighten the clamp, as this will reduce the flow generated by the pump. On the other hand, if does not walk at all, try and reduce the tension by turning the screw anti-clockwise. The tube clamp on the discharge side should always be retracted as far as possible.

5 Assembly of the Verderflex[®] Smart-F pump

The major components of a Verderflex[®] Smart-F pump are:

- Pumphead
- Mounting Flange
- Mounting Frame
- Motor and gearbox

A typical Verderflex[®] Smart-F will require a running torque of approximately 4 Nm per channel. The Verderflex[®] Smart-F series uses an industrial gearbox with a final speed of up to 240rpm and usually this has an integral motor of 0.25kW or 1/3 HP. Please note that due to two internal bearings in the pumphead, no radial loads need to be considered. The standard gearbox output shaft diameter is 20 mm, with a shaft length of 40 mm. The PCD of the gearbox bolts should be between 90 and 100 mm. Align the key into the keyway of the coupling and the gearbox shaft.

Push the keyway to hex coupling onto the gearbox output shaft.



Note the 'Top' mark, which must be on the upper side of the flange to ensure that the pumphead is mounted the correct way round.

Bolt the mounting frame to the mounting flange using the 4 tapped holes.

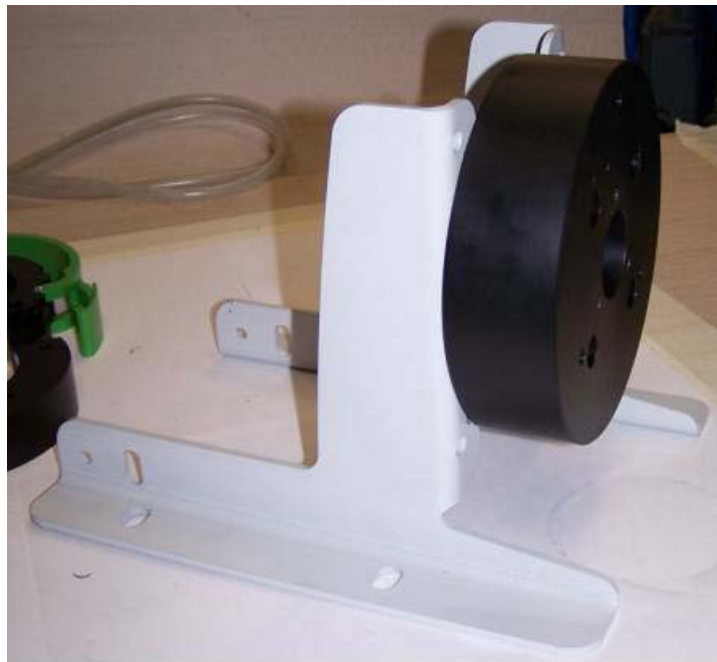

Mount and secure the gearbox using the four slotted holes. The gearbox must be mounted from the mounting frame side.



Next, fit the pumphead following the instruction given above. The three outer tapped holes are for the S30 & S40 heads, whilst the inner tapped holes are for the S20 heads.

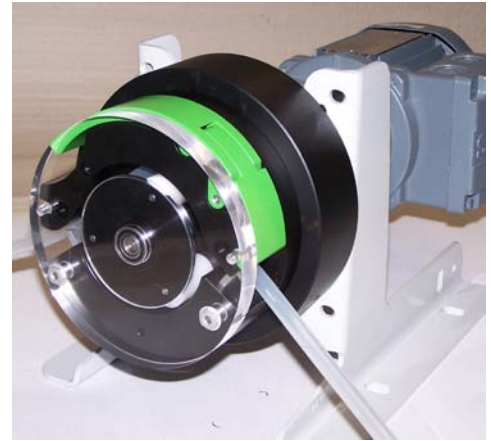
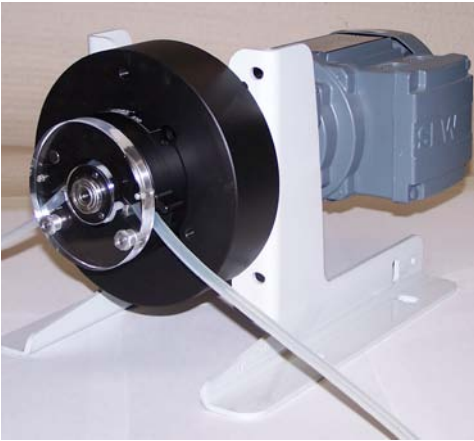

5.1 Use of the Smart F-Series with Inverters & SCADA Systems

The Verderflex® Smart F-Series pump uses an industry standard gearbox & motor and as such can be easily controlled by either a motor mounted or stand alone inverter or variable frequency drive (VFD).

Similarly, the Verderflex® Smart F-Series can be readily interfaced with external control systems such as 4-20mA current loops, distributed control systems (DCS) or supervisory control systems (SCADA) with different communication protocols including MODBUS®, PROFIBUS® etc by means of optional communication modules fitted into the inverter.

Such devices should be installed in accordance with their manufacturer's instructions.

6 Tube Selection and Operation Parameters

For pump curves and flow correction charts please refer to appendix 1

Guidelines to select a suitable tube:

PUMP HEAD SIZE	MINIMUM INNER DIAMETER	MAXIMUM INNER DIAMETER	WALL THICKNESS
S20	1.6 mm (1/16 ")	8.0 (5/16 ")	1.6 or 2.4 mm (1/16 or 3/32 ")
S30	6.4 (1/4 ")	15.9 (5/8 ")	3.2 mm (1/8 ")
S40	9.6 mm (1/3 ")	25.4 mm (1 ")	3.2 or 4.8 mm (1/8 or 3/16 ")

Please note that the S20 and S40 pump heads are by default, supplied with saddles for 2.4 mm and 4.8mm wall thickness respectively. If the S20 and S40 heads are operated with smaller wall thickness tubes (i.e. 1.6 mm or 3.2 mm respectively) then the pump will not generate any suction lift or discharge pressure. For proper operation a separate saddle is required.

If saddles for 1.6mm / 3.2mm wall thickness tubing are used with 2.4mm / 4.8 mm wall thickness tubes this will lead to shortened tube life.

6.1 Chemical Compatibility Testing

Data for a wide range of tube materials are available on [.verderflex.com](http://verderflex.com)

In case of unknown chemical compatibility of the tube and the product being pumped a soaking test should be carried out. This can be achieved using the following method:

- Cut a sample of tubing and measure it's length and wall thickness
- Leave a piece of the tube submersed in the fluid in question for a week.
- Assess the dimensions of the test pieces: Swelling (increased size and/or thickness) and softening / hardening indicate that the tube material is not suitable for this application.

Ideally this test should be done at elevated temperature, as this will speed up any chemical reaction between the tube material and the fluids. For advice on appropriate tube materials contact either Verderflex[®] or your local Verder distributor.

Verderprene and platinum cured Silicone tubes have very good fatigue life, but are limited in their chemical compatibility. However fluorinated materials, such as Viton[®] or Fluran[®] might have better chemical resistance but are limited by their fatigue life.

- To avoid a loss of flow, keep the suction line and pressure line as short as possible. Rigid suction and discharge lines should, where possible, be straight without any fittings or elbows and should be over-sized relative to the tube size being used.
- For a longer tube life, operate the pump at low speed and with large inner tube diameters.
- Pumping or dosing of viscous fluids is best done at low speeds using a large bore tube. Please note that an inner diameter / wall thickness ratio > 4 may lead to reduced performance.
- When pumping fluids with a solid content, please bear in mind that narrow bore tubes are likely to block.
- Most tube materials have a maximum operating temperature in excess 100°C (212°F).

⚠ WARNING

- When pumping fluids at high temperature, the operator should be protected from any hot fluids which may escape at fittings or bursts.

Fluran[®] is a registered trademark of Saint-Gobain Performance Plastics
Viton[®] is a registered trademark of DuPont Dow Elastomers

6.2 Reducing Pulsation

As with any positive displacement pump, the Verderflex[®] Smart-F pump will generate pulsation. While this is not an issue for general transfer applications, pulsation may reduce the accuracy of the pump in dosing or batching applications or affect fragile/highly shear sensitive products such as those used in the biotechnology industry. Verderflex[®] offers two solutions that will reduce, pulsation:

6.2.1 Use of a six-roller rotor

- A six-roller rotor will generate higher frequency pulsation. As pulses then partially overlap, the overall amplitude of pulsation will be greatly reduced. Please note that the use of six-rollers will reduce the flow by approximately 30% as compared to the three-roller head using the same sized tube and pump speed.

6.2.2 Use of two-channel pump head

- Assuming that the rotors in the two channels are staggered, as shown in the drawing below, and that the flow is split in front and merged past the pump head, pulses will overlap and cancel each other out. This option can also be selected if a large flow is required.

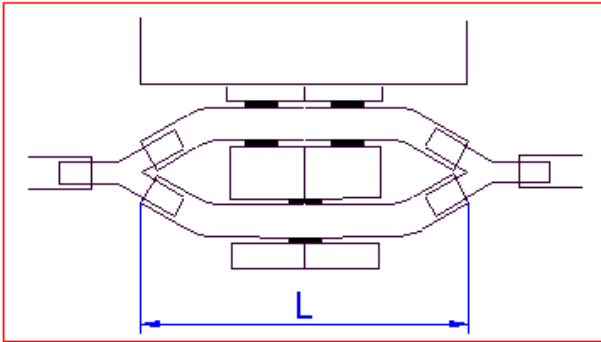

View of the pump head from above
(without the tube saddle):

Please note that the length of tube
passing through both pump heads must
be the same [L].

- We recommend that only Y-pieces can be used to split and merge the fluid stream.

7 Pump Curves

Pump Curves have been determined under ideal laboratory conditions in our test facilities using Verderprene tubes. The flow generated is affected by a number of parameters, for example the nature of the fluid, suction conditions, discharge conditions etc. In many cases the actual flow produced within a system will be lower than the flow shown here.

7.1 FREE FLOW CURVES

The Free Flow Curves cover the standard tube saddles and tube sizes; curves for other sizes can be made available on request.

Free Flow Pump Curve

Verderflex[®] Smart-F S20 Head 2.4mm Walled Tube

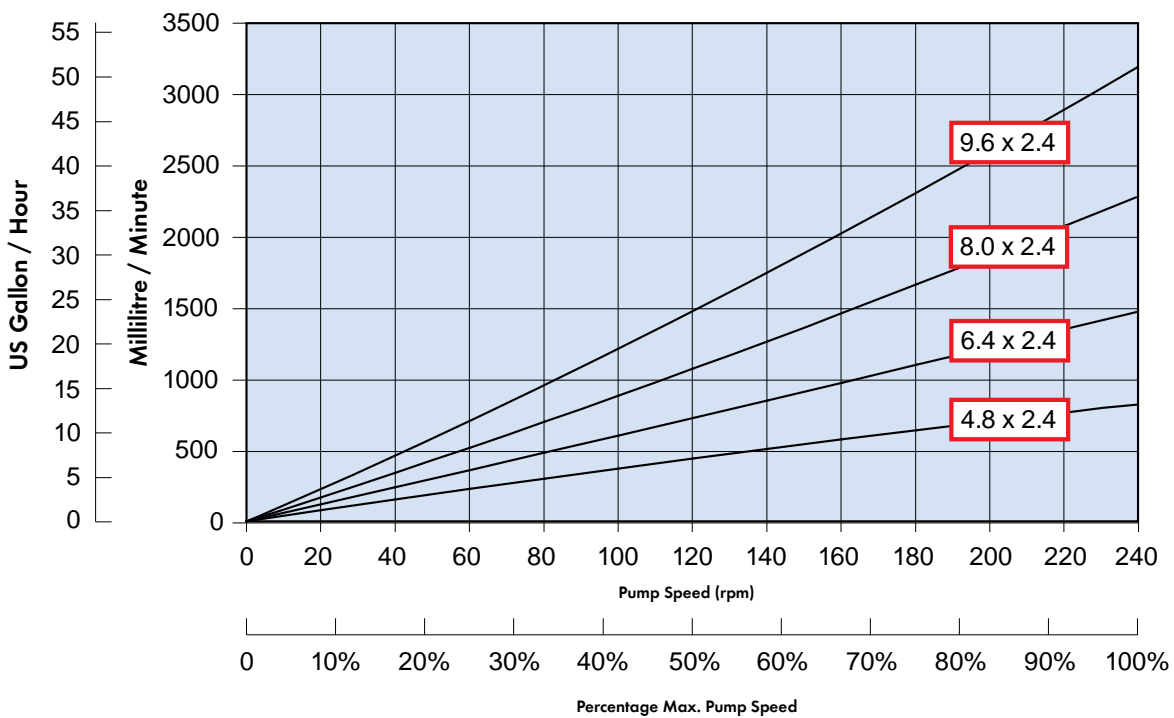

Free Flow Pump Curve
Verderflex[®] Smart-F S30 Head 3.2mm Walled Tube

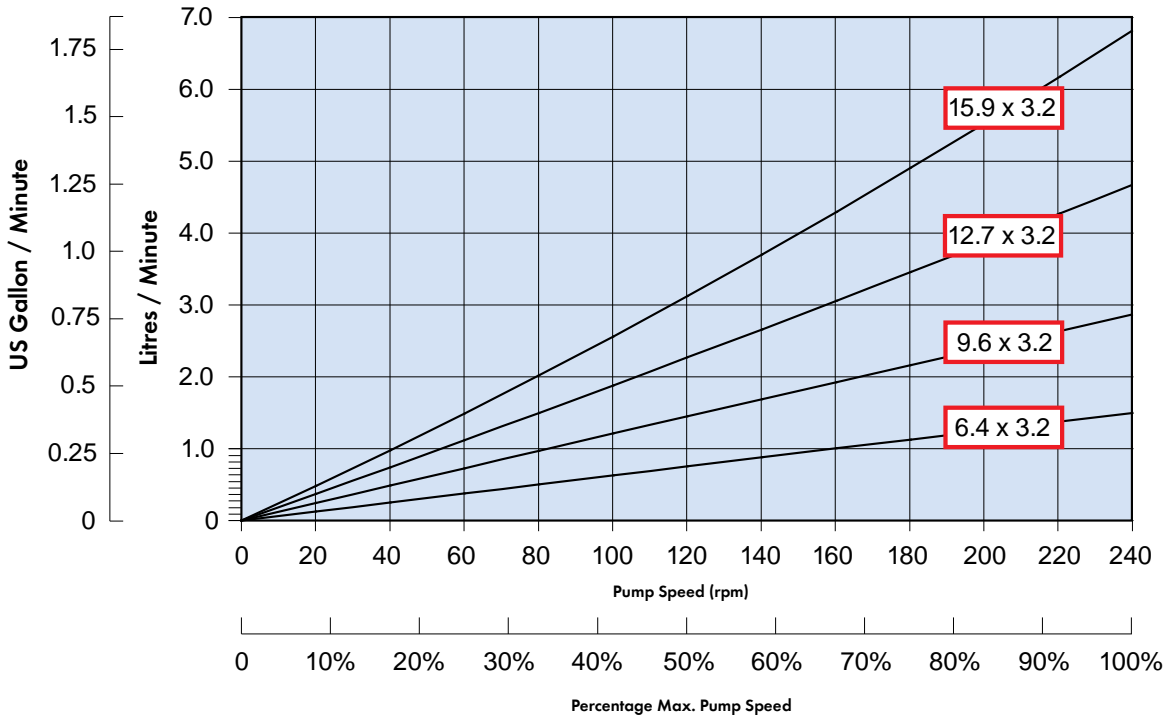

Free Flow Pump Curve
Verderflex[®] Smart-F S40 Head 4.8mm Walled Tube

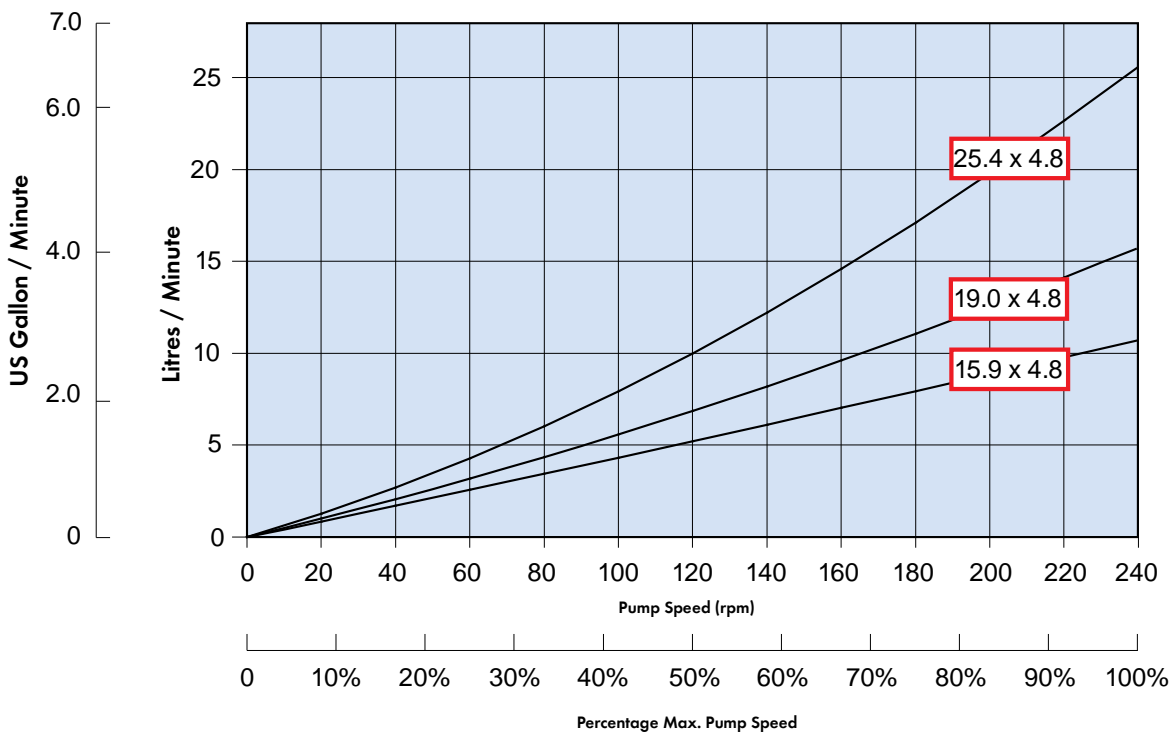

7.2 SUCTION CORRECTION CURVES

Tested Methodology

The suction head loss correction curves were determined by pumping water out of a partially evacuated pressure tank. -0.5-bar pressure (50% vacuum) is the same as the pump lifting water 5 m into the pump. Data was collected at a pump speed of 240 rpm. The pump speed does not affect the suction performance of the pump.

The curves are presented with the suction pressure and lift (in mWc & ftWc) on the x-axis and the percentage nominal flow on the y-axis. For example, on the S20 head, a 6.4*2.4 Verderprene tube, lifting water 4 metres (-0.4 bar), would generate approximately 93% of it's free-flow predicated flow as compared to the nominal capacity under free flow condition. It is therefore recommended to speed up the pump by approximately 7% to compensate for the losses.

S20 Suction Loss Curves for 2.4mm walled tubes

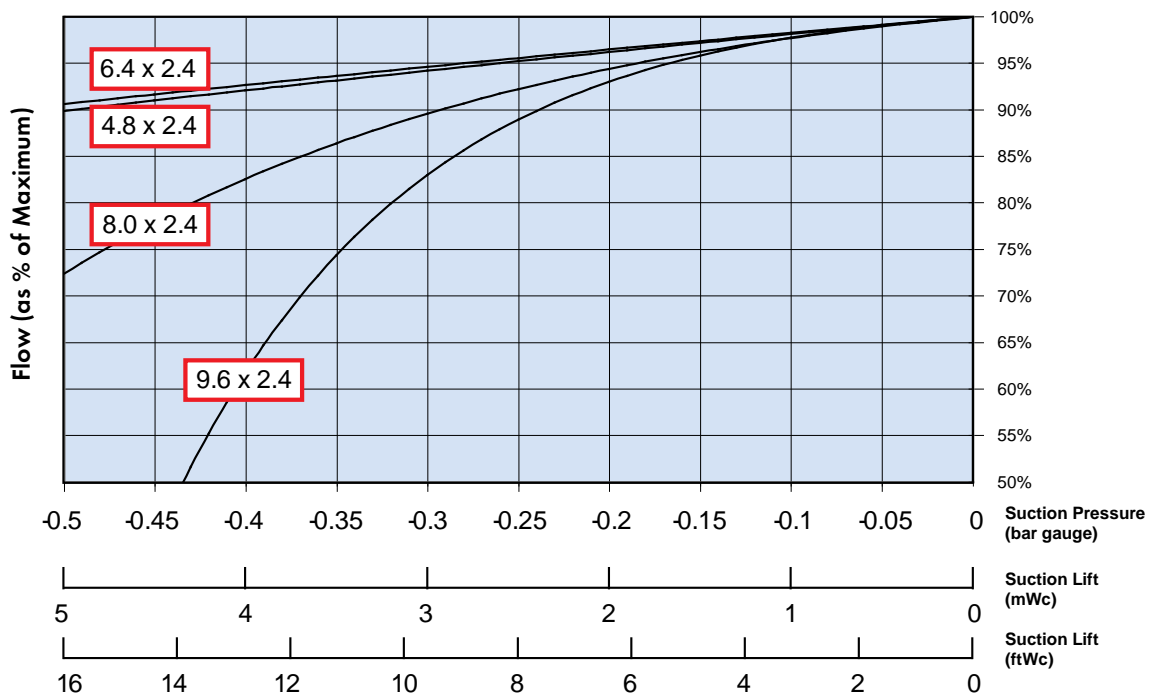

S30 Suction Loss Curves for 3.2mm walled tubes

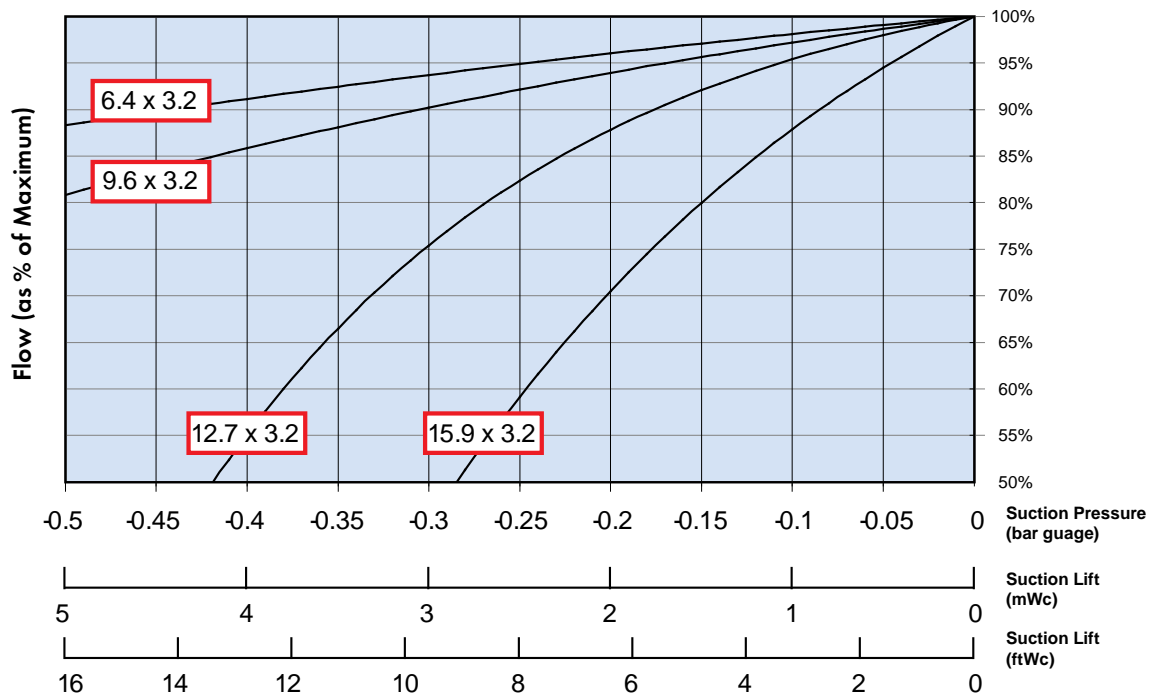

S40 Suction Loss Curves for 4.8mm walled tubes

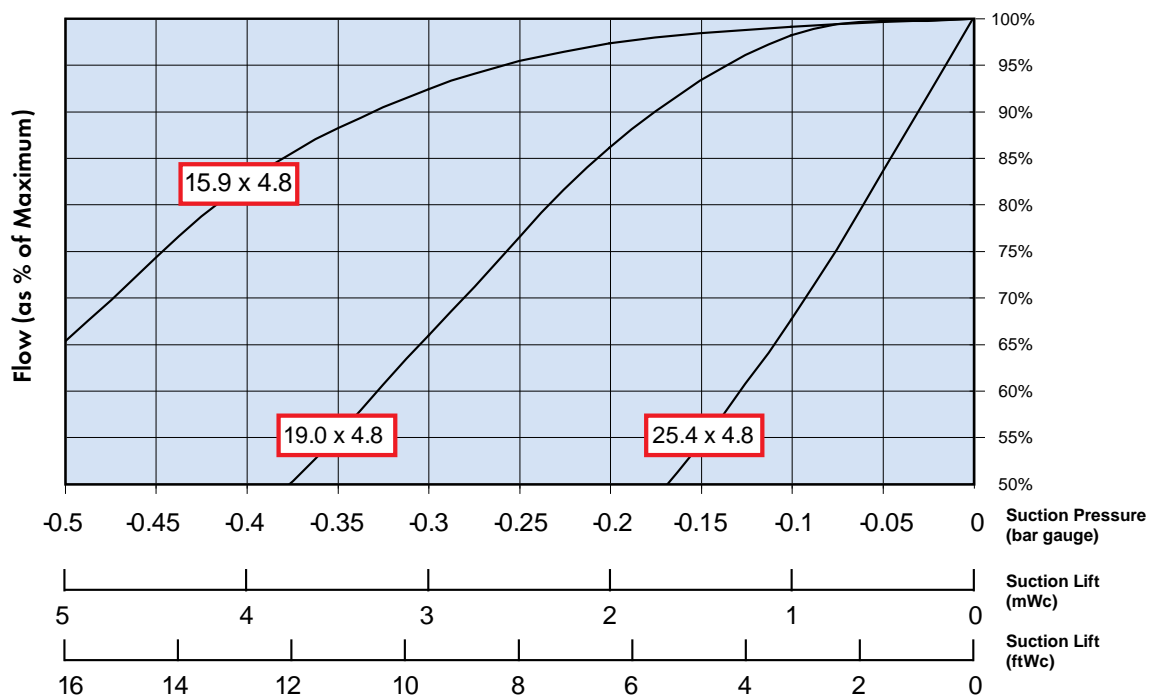

7.3 Discharge Pressure Limitation

Tested Methodology

Water was pumped into a pressurised tank to determine the pump performance against discharge pressure. Tests showed that up to a critical pressure the flow only depends on the pump speed, not the discharge pressure, and no correction needs to be applied.

Beyond this critical pressure, the flow rapidly drops. The table below gives the tube dimension, ratio of inner diameter / wall thickness, the critical pressure and a maximum recommended working pressure for Verderprene. The maximum working pressure is defined as ¼ of the burst pressure.



During our tests we routinely worked at pressures in excess of the recommended pressure. However, when working above the recommended pressure, the user must be aware that the tube's elastic limit (the point where the material changes from elastic to inelastic deformation) is not well defined. Therefore there is no way to predict when the material will overstretch and how far it will overstretch without a burst! Once overstretched, the tube will not recover and must be disposed off.

PUMP HEAD	WALL THICKNESS	TUBE DIAMETER	ID / WALL RATIO	CRITICAL PRESSURE / bar	MAX. WORKING PRESSURE / bar
S20	1.6	3.2	2	<<<<1	1.8
S20	2.4	4.8	2	<<<<1	1.4
S20	2.4	6.4	2.67	<1	1.4
S20	2.4	8.0	3.33	~1.25	1.2
S20	2.4	9.6	4	~1.75	1.1
S30	3.2	6.4	2	<<<1	1.8
S30	3.2	9.6	3	<<<1	1.3
S30	3.2	12.7	4	~1	1.1
S30	3.2	15.9	5	~1.75	0.9
S40	4.8	15.9	3.33	1.1	1.2
S40	4.8	19.0	4	1.1	1.1
S40	4.8	25.4	5.33	1.5	0.8

Shaded rows indicate tube dimensions, which have very low discharge pressure. When discharge head is an important consideration then we advise the user to select tubes one or two sizes up and adjust the pump speed accordingly.

When comparing the discharge and suction performance it becomes clear that the tube that provides good suction (low ratio of inner diameter / wall thickness) is poor for discharge pressure (critical pressure very low).

Higher discharge pressure of up to 75 bar / 100 PSI can be achieved using specially adapted pump heads and a special higher pressure tubing. Any interested customers are invited to contact VERDER or the local Verderflex distributor.

All performance and flow correction charts were determined under ideal laboratory conditions with reference line sizes. Actual performance may vary due to the installation and should be determined for each pumping situation.

VERDER does not assume any responsibility or liability for any advice furnished by it, or for the performance or results of any installation or use of the tubes or of any final product into which the tube may be incorporated.

It is the user's responsibility to ensure the suitability and safety of tube materials for all intended uses. Further test must be conducted in accordance with applicable requirements in order to determine the safety and effectiveness for use of the tube selected in any particular application.

8 Fault Finding

PROBLEM	CAUSE	SOLUTION
Low Flow / low discharge pressure	Ratio of inner diameter / wall thickness too large for the application (tube too 'soft')	Use thicker wall thickness tube with the same inner diameter. This may require a different saddle!
		Run Pump slower with larger inner diameter tube
	Viscosity too high	Use a bigger tube or run the pump slower
	Suction lift too high, resulting in tube not fully returning to fully round	Use thicker wall thickness tube with the same inner diameter. This may require a different saddle!
		Use a bigger pump running slower
	Wall thickness does not match the specifications of the saddle used.	Purchase appropriate saddle or change wall thickness
Discharge pressure too high	Poor flow is caused by excessive backflow, reduce discharge pressure	
Tube walks through pump head	Tube outer diameter too small for the pump head used	Use tube with correct outer diameter.
	Adjust tube clamp tension	See section 4.5 for advice

9 Spare Parts

No. on Diagram	HEAD TYPE	SUPPLIED AS	DESCRIPTION	PART NO.
	S20	Kit	Foot Assembly Kit for S20 Pumps	179.9000
1	S20	Each	S20 Head Front Cover Assy incl Bearing	179.2100
2	S20	Each	S20 3 Roller & Rotor Assembly Complete	179.2200
3	S20	Kit	S20 3 Roller Assembly Kit	179.2300
4	S20	Each	S20 Clamping Assembly	179.2400
5	S20	Each	S20 Saddle 2.4mm WT 3 Roller - no lever	179.0017
6	S20	Each	S20 Lever Assy	179.2600
7	S20	Each	S20 Saddle Assy 2.4 mm WT 3 Roller c/with Lever	179.0086
8	S20	Each	S20 1 ch Shaft	179.2700
5	S20	Each	S20 Saddle 1.6mm WT 3 Roller - no lever	179.0044
7	S20	Each	S20 Saddle Assy 1.6 mm WT 3 Roller c/with Lever	179.0087
2	S20	Each	S20 6 Roller & Rotor Assembly Complete	179.2800
3	S20	Kit	S20 6 Roller Assembly Kit	179.2301
5	S20	Each	S20 Saddle 2.4 mm WT 6 Roller - no lever	179.2501
7	S20	Each	S20 Saddle Assy 2.4 mm WT 6 Roller c/with Lever	179.2502
5	S20	Each	S20 Saddle 1.6 mm WT 6 Roller - no lever	179.2511
7	S20	Each	S20 Saddle Assy 1.6 mm WT 3 Roller c/with Lever	179.2587
	S30	Kit	Foot Assembly Kit for S40 Pumps	179.9001
1	S30	Each	S30 Head Front Cover Assy incl Bearing	179.3100
2	S30	Each	S30 3 Roller & Rotor Assembly Complete	179.3200
3	S30	Kit	S30 3 Roller Assembly Kit	179.3300
4	S30	Each	S30 Clamping Assembly	179.3400
5	S30	Each	S30 Saddle 3.2mm WT 3 Roller - no lever	179.0084
6	S30	Each	S30 Lever Assy	179.3600
7	S30	Each	S30 Saddle Assy 3.2 mm WT 3 Roller c/with Lever	179.0059
8	S30	Each	S30 1 ch Shaft	179.3700
2	S30	Each	S30 6 Roller & Rotor Assembly Complete	179.3800
3	S30	Kit	S30 6 Roller Assembly Kit	179.3301
5	S30	Each	S30 Saddle 3.2 mm WT 6 Roller - no lever	179.3501
7	S30	Each	S30 Saddle Assy 3.2 mm WT 6 Roller c/with Lever	179.1059
	S30	Each	Transformer 330W -	173.0006
	S40	Kit	Foot Assembly Kit for S40 Pumps	179.9001
1	S40	Each	S40 Head Front Cover Assy incl Bearing	179.4100
2	S40	Each	S40 3 Roller & Rotor Assembly Complete	179.4200
3	S40	Kit	S40 3 Roller Assembly Kit	179.4300
4	S40	Each	S40 Clamping Assembly	179.4400
5	S40	Each	S40 Saddle 4.8mm WT 3 Roller - no lever	179.0016
6	S40	Each	S40 Lever Assy	179.4600
7	S40	Each	S40 Saddle Assy 4.8 mm WT 3 Roller c/with Lever	179.0105
8	S40	Each	S40 1 ch Shaft	179.4700
5	S40	Each	S40 Saddle 3.2 mm WT 3 Roller - no lever	179.4502
7	S40	Each	S40 Saddle Assy 3.2 mm WT 3 Roller c/with Lever	179.0095
2	S40	Each	S40 6 Roller & Rotor Assembly Complete	179.4800
3	S40	Kit	S40 6 Roller Assembly Kit	179.4301
5	S40	Each	S40 Saddle 4.8 mm WT 6 Roller - no lever	179.1016
7	S40	Each	S40 Saddle Assy 4.8 mm WT 6 Roller c/with Lever	179.1105
5	S40	Each	S40 Saddle 3.2 mm WT 6 Roller - no lever	179.4503
7	S40	Each	S40 Saddle Assy 3.2 mm WT 6 Roller c/with Lever	179.1095
	S40	Each	Transformer 330W -	173.0006

10 Warranty & Contact Details

Your Verder distributor should have completed a warranty card on your behalf, which is returned to VERDER for registration on the warranty scheme. Please ensure that the distributor has the following details from your initial and any subsequent orders for pump(s) and / or spares:

Pump / spares make and type
Serial number
Application
Fluid to be pumped
Pressure
Temperature
Capacity
Suction
Date of order and delivery
Verder reference

Full completion of this card is essential for you to be covered by VERDER warranty schemes. Please be aware of the declaration that you undertake to use only Verder spare parts including lubricant - this is an essential part of the warranty scheme and is legally binding. The card will also act as a record of your dealings with VERDER and its distributors.

This information will similarly be required if and when you should need to order spare parts from your local Verder distributor.

Should you have cause to return the pump for any reason, please ensure that you inform the local distributor as fully as possible of the details of the problem; the distributor has the necessary documentation for completion of the warranty application to VERDER and is aware that this has to be completed in full before VERDER can examine the application.

Complaints Procedure

VERDER takes its responsibilities to its customers extremely seriously and prides itself on its comprehensive complaint procedures. Should you be dissatisfied with your Verder pump(s) or with any aspect of the service you have received, then please contact your local Verder distributor in the first instance to discuss the matter fully.

The distributor will then take the matter up with Verder, acknowledging his actions to the customer and indicating a time scale by which he will reply. You will receive a response from the distributor with VERDER initial comments and proposed plan of any further action. If you feel that your complaint has still not been resolved satisfactorily, you should contact VERDER directly at the address given overleaf.

Verder Group Literature

Verder supplies its range of Group literature and product documentation in a number of languages and variety of software packages - please advise your Verder distributor if you are interested in receiving other information on Verder, indicating in which languages and format.

Verder and its distributors undertake to conduct all its dealings with you as comprehensively, courteously and promptly as possible. Customer care is one of Verder's top priorities

Distributor Contact Details:

Verder Contact Details:

VERDER
Whitehouse Street
Leeds LS10 1AD
ENGLAND, UK
Tel: (+44) 113 222 0250
Fax: (+44) 113 222 0291
E-mail: [@verderflex.com](mailto:)
Web Site: .verderflex.com